

COPY RIGHT & CONFIDENTIAL THIS DOCUMENT IS THE EXCLUSIVE PROPERTY OF BEML & CONTAINS CONFIDENTIAL INFORMATION. THIS DOCUMENT OR ITS CONTENTS SHALL NOT BE USED, REPRODUCED OR DISCLOSED IN WHOLE OR IN PART, WITHOUT PRIOR WRITTEN PERMISSION OF BEML. THIS DOCUMENT & ALL ITS COPIES SHALL BE RETURNED TO BEML ON DEMAND DRAWING RELEASED FROM P.L.M. PHYSICAL SIGNATURE NOT REQUIRED

GRADE No.	VALUE	SYMBOL
N1	0.025	
N2	0.05	
N3	0.1	
N4	0.2	
N5	0.4	
N6	0.8	
N7	1.6	
N8	3.2	
N9	6.3	
N10	12.5	
N11	25	
N12	50	

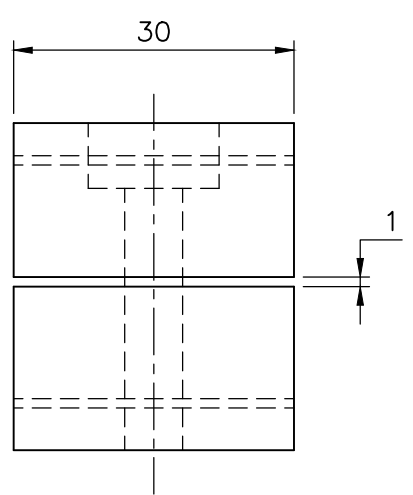
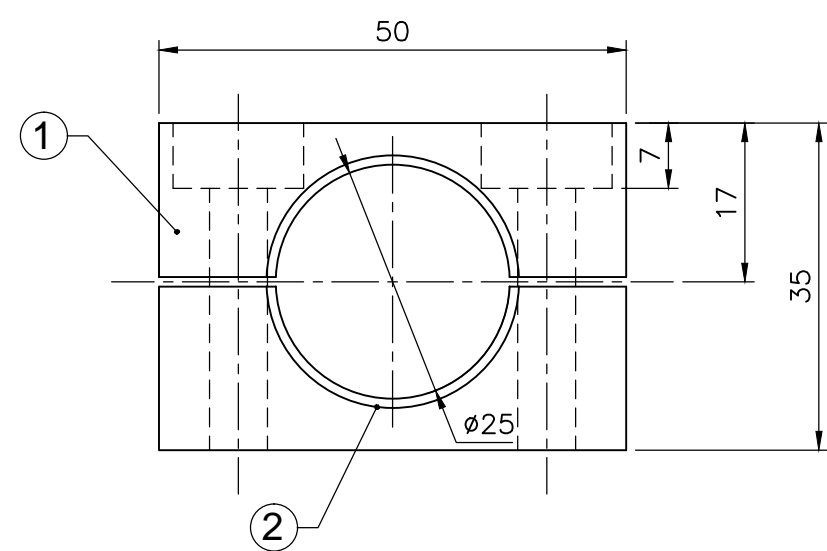
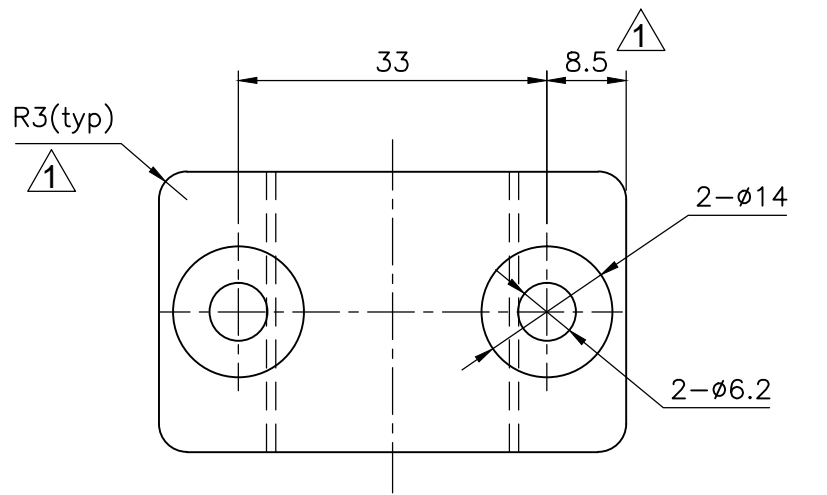

- NOTE:
1. REMOVE ALL SHARP EDGES
 2. FOR CLEATS Min TENSILE STRENGTH: 65 N/mm²
 3. CLEAT SHALL BE FIRE RETARDANT TO V-0 OF UL-94

MACHINING DEVIATIONS FOR LINEAR DIMENSIONS	RANGE	0 - 6	6 - 30	30 - 120	120 - 315	315-1000	1000-2000	2000-4000	ABOVE 4000	RA
	TOLERANCE		±0.1	±0.2	±0.3	±0.5	±0.8	±1.2	±2	±3

FOR DIMENSIONAL TOLERANCES OF SHEET METAL PARTS AND WELDED STRUCTURES, REFER STD. RD-227

UNSPECIFIED TOLERANCE FOR LINEAR AND ANGULAR DIMENSIONS REF. IS 2102 (PT-1) (MEDIUM) QUALITY OF WELD JOINTS REF, RD 230 MEDIUM

VALUES OF SURFACE TEXTURE SHALL BE AS PER COMPANY STD DS. 1012.C.

WELDING SHALL BE CARRIED OUT AS PER IS: 9595-96

STATUS: _____

SL.No.	QTY	PART / STOCK No.	DESCRIPTION	SIZE	COMPANY STD./I.S	Wt. (Kg)
2	2		PACKING	38x30x1 thk	EPDM	
1	2		CLEAT	50x30x17.5	NYLON6	

PRODUCT	BMRCL METRO CARS					
REF DRG						
MATERIAL						
HEAT TREAT.	APPD	VS				
SURFACE TREAT.	REVD					
TITLE	CHKD	SNH				
	DRWN	VISHNU			04.09.19	
	SCALE		SHEET	OF	0	
	DRG No.	926-56216		ALT		

1	DIM R3 ADDED, DIM 8.5 WAS 9.5	DATE	09.09.19	BY	VISHNU	CHKD	SNH	APPD	KCS
ALT.No.	ECN NO/CHANGES	ECN:92610183							

		BEML LIMITED	
--	--	--------------	--