

BEML LIMITED

(A Govt. of India Mini Rathna Company under Ministry of Defence)
BEML Soudha, 23/1, 4th Main Road, SR Nagar, Bangalore 560 027.
Phone 080-22963179 email: cmrm@beml.co.in; cmrm1@beml.co.in.

Ref: BEML/CMRM/TRACKSHOE/FY23-24/01

Date : 19/05/2023

Quotation in Sealed cover is invited for supply of Track shoe profiles to BEML.

Sl no	Stock No	Description	Tender Qty
			Ton
1	110CTB0045	TRACK SHOE, Multiples of 405 MM	31
2	113CTB0056	TRACK SHOE, Multiples of 510 MM	109
3	116CTB0075	TRACK SHOE, Multiples of 575 MM	90
4	125CT00326	TRACK SHOE, Multiples of 575 MM	473
5	130CT00284	TRACK SHOE, Multiples of 625 MM	1017
6	155CTB0025	TRACK SHOE, Multiples of 620 MM	8

Tender publishing Date : 19/05/2023

Tender closing date : 13/06/2023 Time 2:00 PM (21 Days)

- ✧ The Bidder supplies should comply to material, dimensions as per BEML Grade drawings.
- ✧ Tender to be submitted in sealed cover before closing date and time to the below mentioned address. Technical and commercial bids to be submitted in separate sealed cover. Both the sealed covers with quotation should be submitted in One sealed cover mentioning the tender reference.

Purushothama G
Deputy General Manager – Corporate Materials
BEML Limited
Schedule 'A' Company under Ministry of Defence, Govt. Of India
Corporate Office
23/1, 4th Main, Sampangi rama Nagar
Bengaluru 560 027
Telephone: +91-80-22963179 , +91-8618029415

- ✧ Material to be supplied in standard lengths of 5-12 Meters in multiples of dimensions mentioned above.
- ✧ Bidder should also submit their drawing matching to nearest BEML requirement. However, final discretion will be given by BEML. Bidder should mention the corresponding dimensions of their shoes against BEML requirements on BEML sketch and submit along with technical documents. Minor deviation to dimension and

chemistry will be accepted subjected to Bemi discretion. Bemi decision on technical acceptance is final.

- ✧ New bidders should supply sample lot for evaluation within 30 days of order. Sample order quantity will be mutually discussed later.
- ✧ Bidder should submit integrity Pact as per BEML Format attached.
- ✧ This tender is covered under guidelines of PPI Order vide F.No.6/18/2019-PPD and BEML General Terms and conditions.

Terms & Conditions:			
SI No.	Particulars	Terms	Bidder Confirmation (Yes/No)
1	Material Grade	As per BEML Standard. B1201 & B1202	
2	Quote	Rate to be quoted as per tendering unit only, <u>including GST.</u> For overseas bidders currency may be indicated.	
3	Delivery Terms	F.O.B (Seller Sea port) / C.I.F Chennai / F.o.R Bemi K.G.F Shipment mode whether Break-Bulk or Container to be indicated	
4	Delivery Schedule	8-12 weeks from date of PO staggered up to Dec-23	
5	Payment terms	60 days on receipt & acceptance. For MSME firms, as per MSME act.	
6	MOQ	Buyer may quote MOQ, however, final qty is on BEML discretion.	
7	Local content	Firm shall submit the local content 50% as per Make In India for Class I and 20% for Class II Supplier	
8	Mill TC/ NABL TC	Bidder should submit Mill /LAB/ NABL TC.	
9	Mill Authorization Certificate	Stockists/traders should submit Mill authorization certificate, authorizing the bidder to participate for BEML Tenders.	

10	Deferent Clause	PO is subject to deferment, re-scheduling, cancellation, Short / Pre-closure based on equipment sales order.	
11	LD Clause	LD Applicable for late deliveries.	
12	Integrity Pact	Bidder should sign and submit integrity Pact as per Annexure J	
13	EMD	2% of the total tender Value. Rs. 45,63,351/- Online payment link and instructions are given Annexure – A. Any other payment is not acceptable. EMD will be returned once tender is finalised.	
14	Bank Guarantee	Successful Bidder should submit BG to the value of 3% of the PO value. Validity upto 6 months after completion of the contract.	
15	NDA, Non-competition Agreement & Land border sharing declaration.	Bidder should submit NDA, Non-competition Agreement & Land border sharing declaration.	
16	Offer validity	60 days from tender opening date	
17	Price validity	31-12-2023	
18	CEPA	Bidder should disclose applicable custom duty at the time of submitting bid and any rebate/concession etc.	

Bidder Declaration.

I here by confirm to supply as per above terms and conditions.

Bidder Seal & Signature.

Annexure – A

Instructions for payment of EMD

1. Payment Link is below.
<https://www.onlinesbi.sbi/sbicollect/icollecthome.htm>
2. Select → PSU-Public Sector Undertaking
3. Search for → BEML , Select→ BEML LIMITED,CORPORATE OFFICE
4. Select Payment Category → EMD/TENDER FEE
5. Enter details of payment, details of Bank Account for refund and click on next to make online payment of the required EMD amount.
6. Please ensure that online payment of EMD amount is made well ahead of the Tender Closing Date & Time mentioned in the Tender

110 CT 11005

MACHINING DEVIATIONS FOR LINEAR DIMENSIONS								THE REST
ABOVE UP TO AND INCLUDING	6	30	120	315	1000	2000	4000	—
VALUE	± 0.1	± 0.2	± 0.3	± 0.5	± 0.8	± 1.2	± 2	± 3

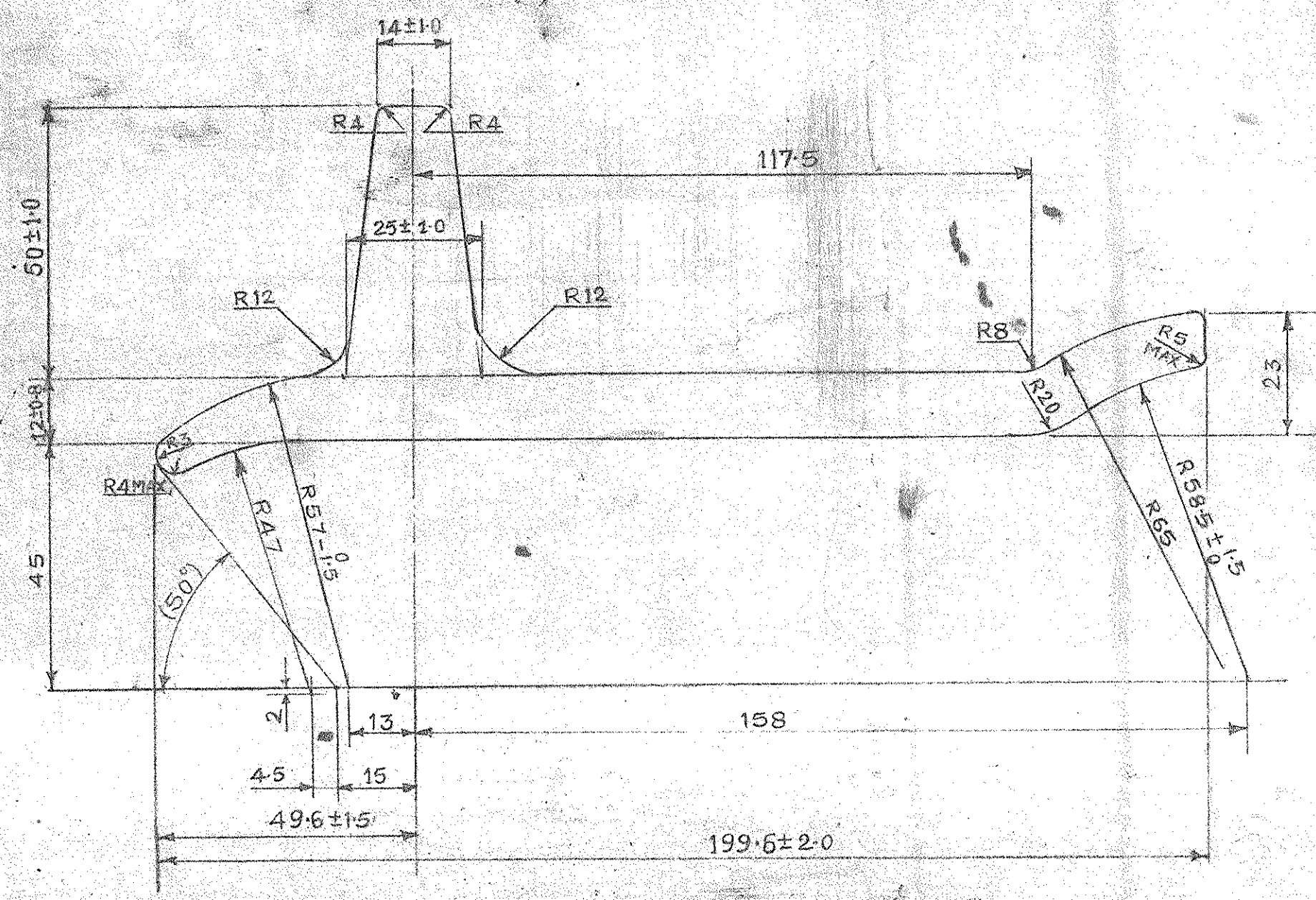

NOTE:-

- FOR MATERIAL AND OTHER DETAILS REFER TO UNIT STANDARD B1201
- DRILLING, NOTCHING & HEAT TREATMENT IS TO BE DONE AS PER DRG. 110 CT 11095

LENGTH 400 ± 2.0

PRODUCT		BD50		NEXT ASSY		110 CT 11001	
USED ON		D50A-15		QTY.		76	
MATERIAL		SEE NOTE					
H.T.							
11000802		1			2010/3/30		
11000180		R&R					
ECN NO.	AMEND No.	SIGNATURE	DATE	TITLE			
				TRACK SHOE (PROFILE)			
APPROVED				BHMAT EARTH MOVERS LTD			
REVIEWED				KGF			
CHECKED				DRG. NO.			
DRAWN				110 CT 11005			
STDS.							
				SHEET No.		1	
				NO. OF SHEETS		1	

COPY RIGHT & CONFIDENTIAL
This document is the exclusive property of BEML and contains confidential information. This document or its contents shall not be used, reproduced or disclosed in whole or in part without prior written permission of BEML. This document and all its copies shall be returned to BEML on demand.

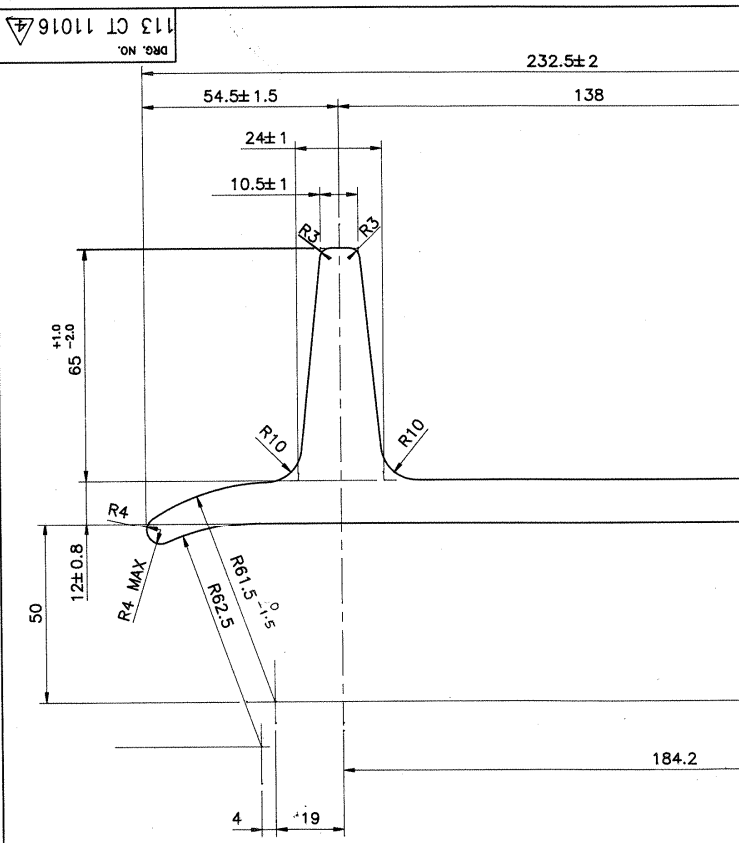

MACHINING DEVIATIONS FOR LINEAR DIMENSIONS							
ABOVE AND BELOW	6	30	120	315	1000	2000	4000
VALUE	±0.1	±0.2	±0.3	±0.5	±0.8	±1.2	±2

- NOTE :-**
1. FOR MATERIAL AND OTHER DETAILS REFER TO UNIT STANDARD B1201-06. ⚠
 2. LENGTH = 510 ± 2
 3. FOR MACHINING DRAWING REFER 113 CT 11008.

NEXT ASSY.				PRODUCT BD65		DESIGN REF.	
				USED ON	QTY	MATL. REFER NOTE	
				BD65	78	H.T. -----	
11300591				11300402		S.T. PST, PRI031-C	
AMEND NO.				SIGNATURE		DATE	
DRA/ECN				NAME		TITLE	
APPROVED				QIBAL PASHA		991213	
REVIEWED				K. SHARATH BHAI		991213	
CHECKED				K. SETHILKUMAR		991211	
DRAWN				K. SHANMUGAM		991213	
				BHM		BHM	
				BHARAT EARTH MOVERS LTD.		DRG. NO.	
				K G F		113 CT 11016	
						NO. OF SHEETS 1	
						SHEET NO. 1	
						WT. In kg 15.85	
						SCALE 1:1	
						1HCT1101	

		4		3		2		1		THE REST	N13 ✓
MACHINING DEVIATIONS FOR LINEAR DIMENSIONS											
APPROX. VALUE	6	30	120	315	1000	2000	4000				
VALUE	±0.1	±0.2	±0.3	±0.5	±0.8	±1.2	±2	±3			

△ 3. DUMMY ISSUE CREATED (05 AND 06) AUTOMATICALLY WHEN CONVERTING FROM LEGACY TO SAP.

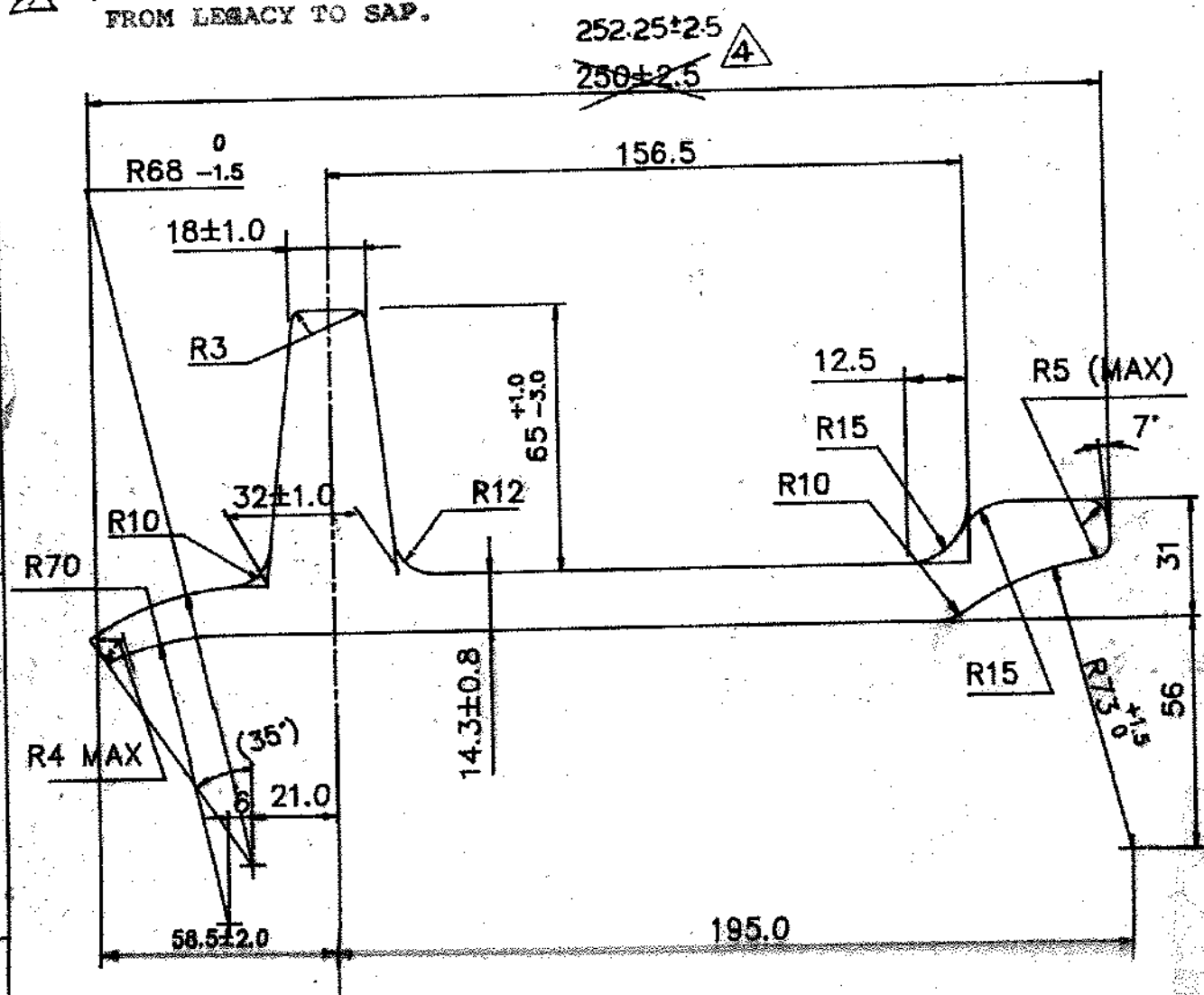

NOTE: -

- FOR MATERIAL AND OTHER DIMENSIONAL DETAILS REFER UNIT STANDARD ~~B1201-00~~ B1201. △
- DRILLING, NOTCHING & HEAT TREATMENT IS TO BE DONE AS PER DRG. 116 CT 11124.

LENGTH 560±2.0

REPLACES:		ALT/REPLACED:		NEXT ASSY: 116 CT 01009	
PRODUCT D80				DESIGN REF. ---	
USED ON		QTY	MATERIAL SEE NOTE		
D80A-12		76	H.T.		
11600786	△	2	24/03/20		
11600245	△	1	22/03/18		
11600245	△	RAR			
AMEND NO	SIGNATURE	DATE	TITLE		
ECN NO	APPROVED B. BABU	22-01-27	TRACK SHOE (PROFILE)		
	REVIEWED		BHARAT EARTH MOVERS LTD		
A	CHECKED NIRANJAN	22-01-25	DRG NO.		
	DRAWN VISHWANATH	22-01-25	KGF 116 CT 11002 △		
	STDS SHANMUGAM	22-01-27	16CT1100		

This document is the exclusive property of BEML and contains confidential information. This document or its contents shall not be used, reproduced or disclosed in whole or in part, without prior written permission of BEML. This document and all its copies shall be returned to BEML on demand.

COPY RIGHT & CONFIDENTIAL

MACHINING DEVIATIONS FOR LINEAR DIMENSIONS

ABOVE UP TO AND INCLUDING	-	6	30	120	315	1000	2000	4000	THE REST	50
VALUE	±0.1	±0.2	±0.3	±0.5	±0.8	±1.2	±2	±3		✓

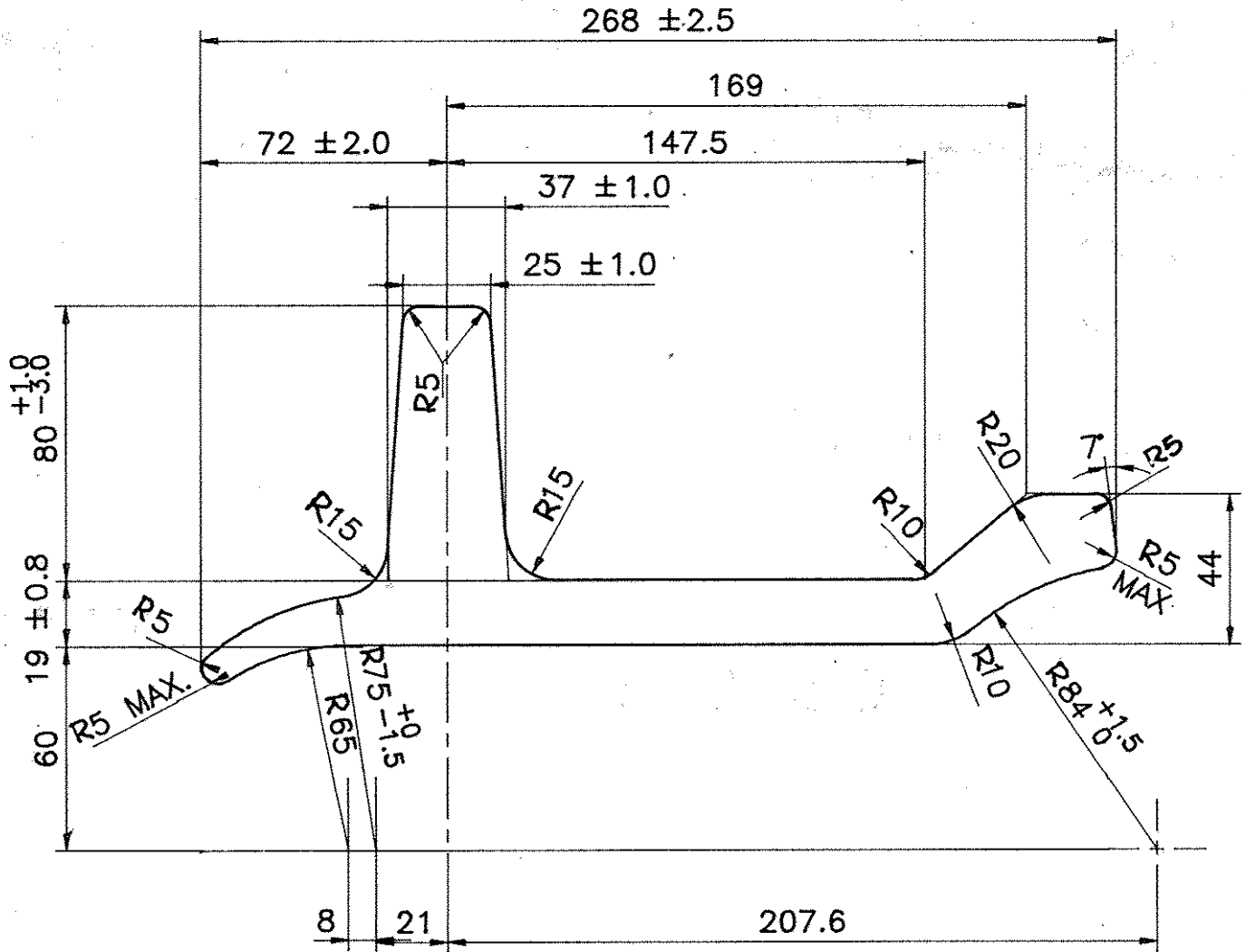

NOTE:-

1. FOR MATERIAL AND OTHER DETAILS REFER TO STD B 1202-00
2. FOR MACHINING REFER DRG.NO. 125 CT 11172

LENGTH=560 ± 3.00

NEXT ASSY.

				PRODUCT	BD155	DESIGN REF.			
				USED ON	QTY	MATL:	SEE NOTE		
				BD155	82	H.T.	-		
				S.T. PST. PRI031-C				Wt. in kg	SCALE
								-	1:2
12500550	△	R&R		TITLE				SHEET NO.	1
	AMEND NO.	SIGNATURE	DATE	TRACK SHOE(PROFILE)				NO. OF SHEETS	1
DRA/ECN	NAME			BHARAT EARTH MOVERS LTD.				DRG. NO.	
APPROVED	M.S.S	M.S. Srinivas	96.9.14	KGF				125 CT 11001A	
REVIEWED	HRS	H.R.S.	96.9.14	GEC				1KCT1100	
CHECKED	HRS	H.R.S.	96.9.14						
DRAWN	CAD								
STDS.									

DRG. NO. 130.CT.11008

MACHINING DEVIATIONS FOR LINEAR DIMENSIONS									THE REST
ABOVE UP TO AND INCLUDING.	6	30	120	315	1000	2000	4000	4000	
VALUE	± 0.1	± 0.2	± 0.3	± 0.5	± 0.8	± 1.2	± 2	± 3	

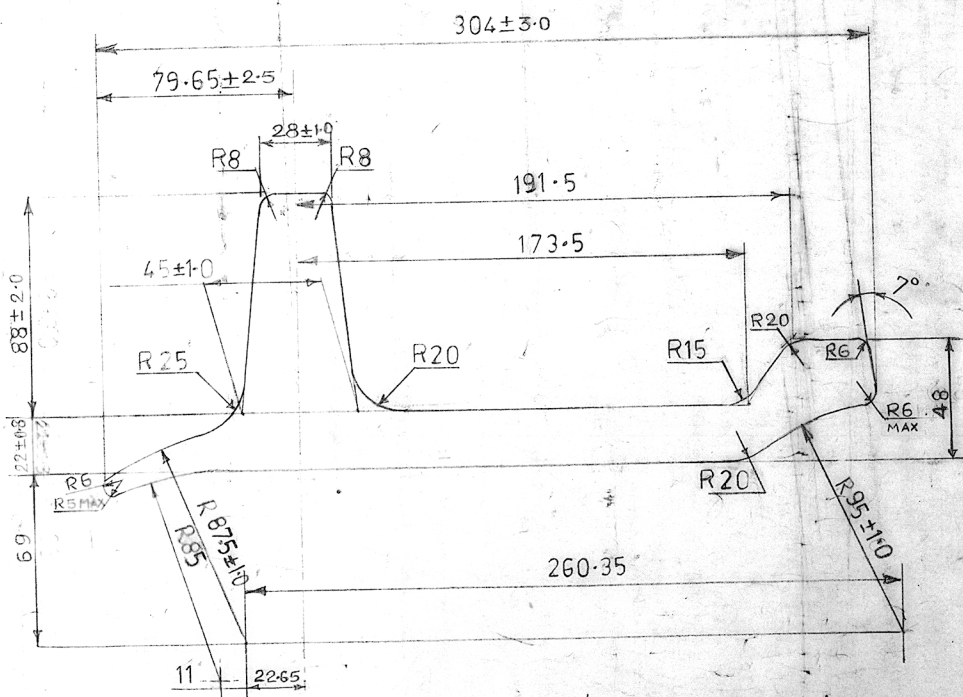

NOTE:-

- FOR MATERIAL AND OTHER DETAILS REFER TO ~~B.E.M.L. STD 01-04-07~~ UNIT STANDARD-B1202-00.
- DRILLING, NOTCHING & HEAT TREATMENT IS TO BE DONE AS PER DRG. 195-32-11452/1

LENGTH - 610 ± 3.0

PRODUCT		D355A-3		DES. REF.	
USED ON	QTY.	MATERIAL			
D355A-3	78	SEE NOTE			
		H.T.			
AMEND. No.	SIGNATURE	DATE	TITLE		
1		8/10/07	TRACK SHOE		
APPROVED		8/10/07			
REVIEWED					
CHECKED		8/10/07			
DRAWN		8/10/07			
BDD/106 DT.1987-11-02		KGF		DRG. NO. 130 CT 11008	

155 CT 11001/2
DRG. No.

MACHINING DEVIATIONS FOR LINEAR DIMENSIONS									THE REST	50/
ABOVE UP TO AND INCLUDING	6	30	120	315	1000	2000	4000	4000		
VALUE	± 0.1	± 0.2	± 0.3	± 0.5	± 0.8	± 1.2	± 2	± 3		

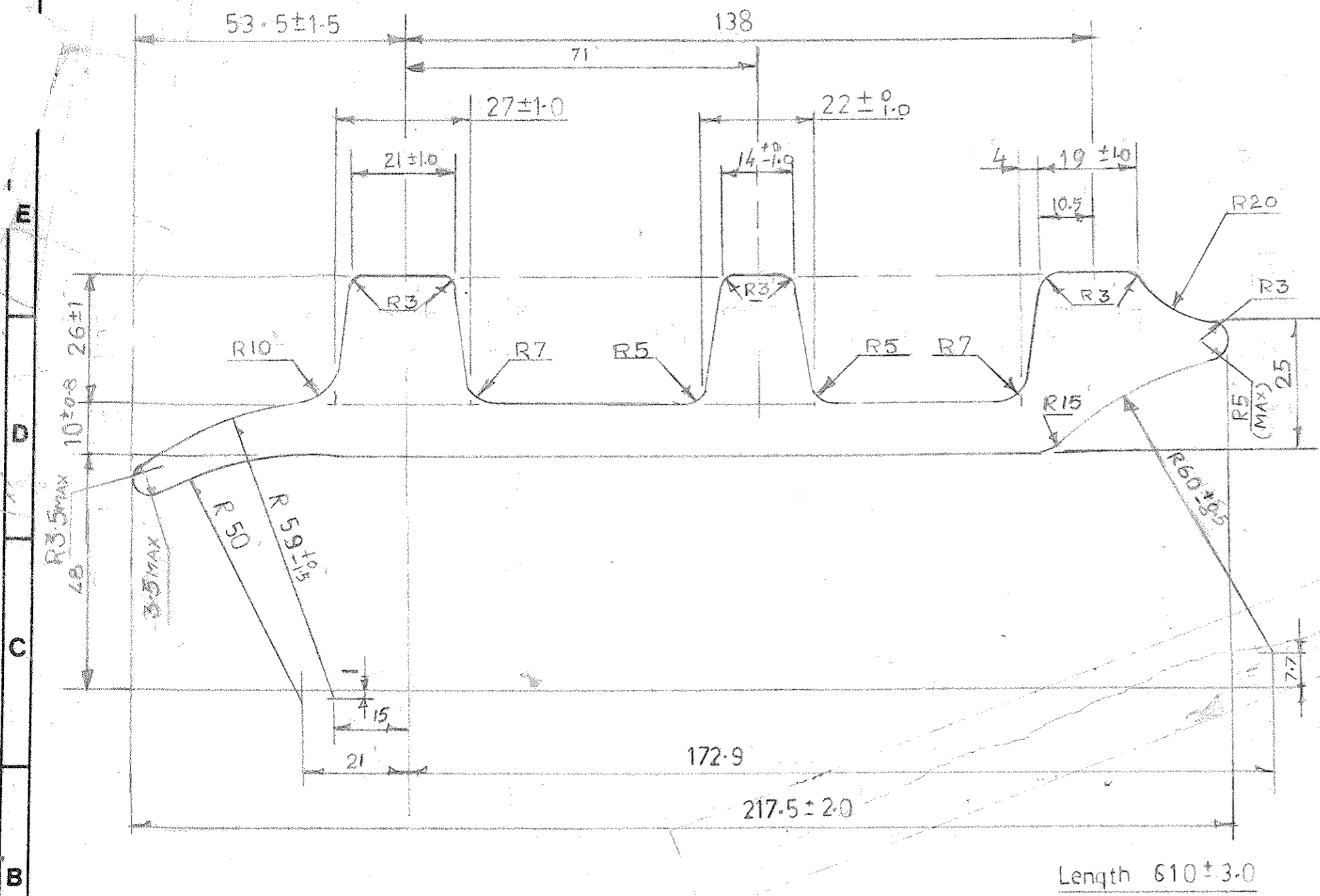

As Reinstated Ref: 15500309/1/3/22
Supplied as per
Order No. 11164

NOTE:-
1. FOR MATERIAL AND OTHER DETAILS REFER TO
 ▲ ~~B.E.M.L. STD. 01-04-09 ZL~~ UNIT STANDARD- B1201-00.
 2. DRILLING, NOTCHING & HEAT TREATMENT IS TO BE
 DONE AS PER DRG. ~~205-32-51131~~ 155 CT 11164
 ▲

PRODUCT		BE220LC		DES. REF.		205.32.51131	
USED ON		QTY.	MATERIAL		 See Note. H.T.		
BE220LC		34102					
15500309	▲ 2	95.01.23			Wt. IN Kgs SCALE 17.50 NTS		
	▲ 1	88/05/07			SHEET No. 1 NO. OF SHEETS 1		
AMEND No.	SIGNATURE	DATE	TITLE		TRACK SHOE BHARAT EARTH MOVERS LTD. K G F DRG. NO. 155CT11001/2		
APPROVED		89/10/28					
REVIEWED							
CHECKED		87/10/28					
WN		87/10/23					

BDD/106 DT.1987-11-02 STDS.



बी ई एम एल
beml
NEW FRONTIERS. NEW DREAMS

UNIT STANDARDS

TITLE:

**HOT ROLLED LOW ALLOY STEEL
FOR TRACK SHOES**

AMENDMENT No. 01

DATE: 2019-08-21

STD No. B1201

AMENDMENT SHEET - 1/1

ISSUE No. 02

In page No. 3 of 3, clause 8 shall read as follows:

8. SUPPLY CONDITION:

Track shoes shall be supplied in “As Rolled” condition with a hardness of 255 BHN max.

Ref: Mail from AGM(CMRM), dated 27.02.2019.

APPROVED BY:

GE



1. SCOPE :

This specification covers the requirements of hot rolled low alloy steel for track shoes of dozers, shovels and excavators.

2. CHEMICAL COMPOSITION, PERCENTAGE :

Carbon	: 0.28 ~ 0.34	Sulphur	: 0.03 max.
Manganese	: 1.00 ~ 1.30	Phosphorus	: 0.03 max.
Silicon	: 0.15 ~ 0.35	Titanium	: 0.025min.
Chromium	: 0.25 max.	Boron	: 0.0005 ~ 0.003

3. ALLOWABLE VARIATION IN CHEMICAL COMPOSITION :

C = ± 0.02 , Si = ± 0.02 , Mn = ± 0.04 .

Chemical analysis shall be performed in accordance with IS:228.

4. NOTE :

- a) One sample track shoe per heat shall be selected at random and tested for chemical composition. When the chemical composition is within the allowable limits as specified in clause-2, the entire lot with same heat number shall be accepted. In case the chemical composition is not within the allowable limits as specified in clause-2, one more Track shoe shall be tested for chemical composition. If the result of retest for chemical composition is within the allowable variation as mentioned in clause-3, the batch shall be accepted.

POSITION TO EXTRACT SAMPLE FOR CHEMICAL ANALYSIS :

FOR D50A-15, D80A-12,
D120A-18 & D56E-8

FOR D31A-17 ONLY

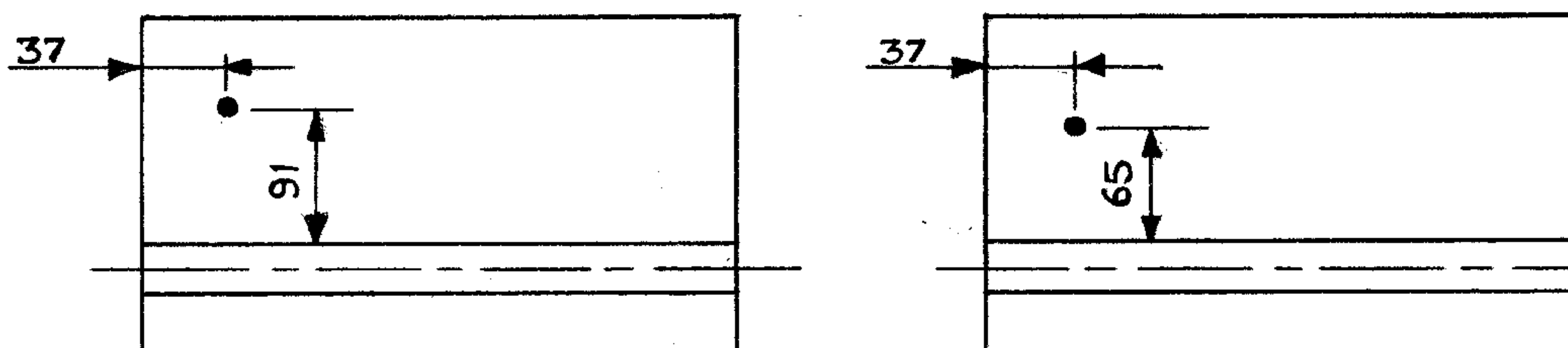
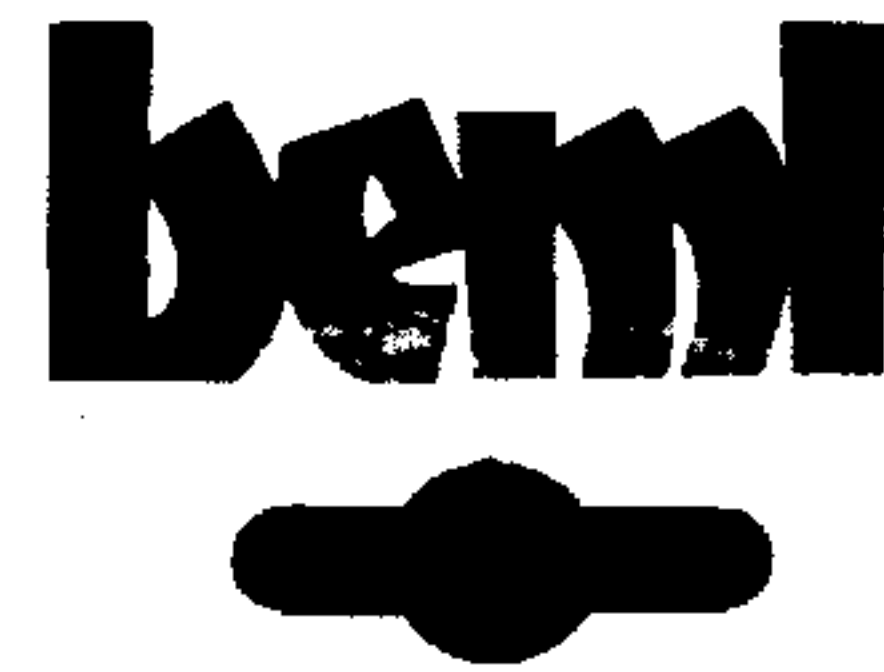

Fig-1 (Dimensions in mm.)

PREPARED BY: 	ISSUE NO: TWO	REPLACEMENT FOR: EM STANDARDS : 01-04-03 01-04-09 01-04-10	REF:
APPROVED BY: 	ALTERED BY: 		



FOR 5013, 8023, PC220, PC300

FOR PC650 ONLY

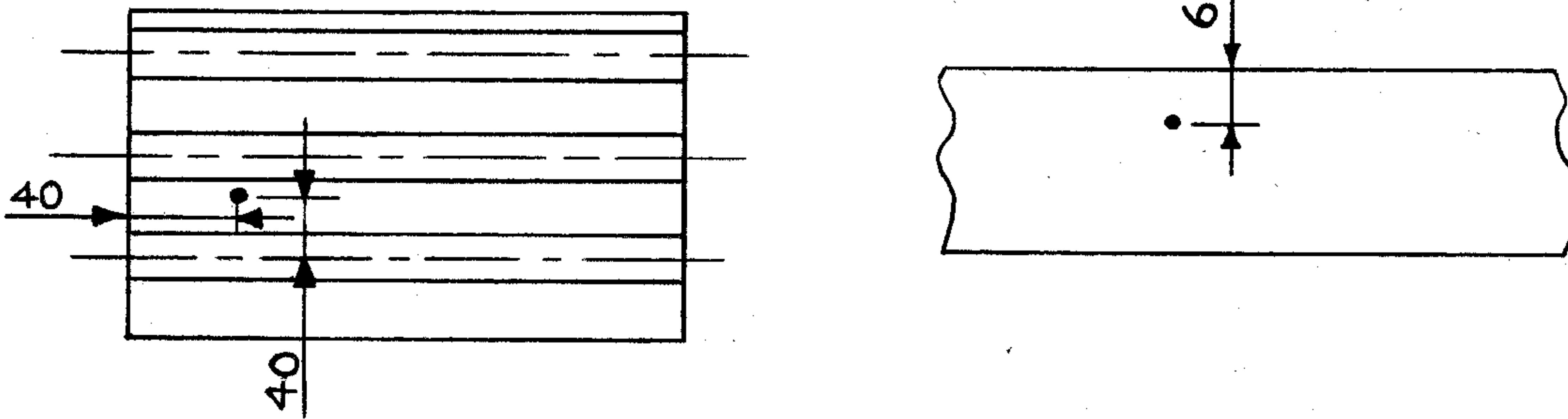

Fig-2 (Dimensions in mm)

- b) If a lot is rejected based on the result of retest for chemical analysis, joint analysis may be made only once, if requested by the supplier. On such occasions one more additional Track shoe (on third sample) shall be tested and if the result of joint analysis (on third sample) is within allowable limits as specified clause-2, the lot shall be accepted.

5. GRAIN SIZE :

Grain size shall be ASTM No : 5 ~ 8.

6. INCLUSION CONTENT :

Test in accordance with as per clause-2 of IS:4163-1982 - "Method for determination of inclusion content steel by Macroscopic method"

7. HARDENABILITY :

- a) Hardenability shall be determined in accordance with IS:3848.
- b) Requirement : Distance in mm from quenched end

<u>Distance (mm)</u>	<u>Hardness (HRC)</u>
1.5	49 ~ 55
7.5	38 ~ 44
15	28 min.

This document is the property of Bharat Earth Movers Limited, India. It must not be used directly or indirectly in any way detrimental to the interest of company without written consent of the proprietors.

beml

UNIT STANDARDS

KGF COMPLEX - B

B1201

TITLE: HOT ROLLED LOW ALLOY STEEL
FOR TRACK SHOES

PAGE NO. 3 OF 3

DATE: 1992-11-19

8. SUPPLY CONDITION :

Track shoes shall be supplied in normalised condition.

9. DIMENSIONAL REQUIREMENT AND TOLERANCES :

- a) The track shoe section must conform to the dimensions/tolerances specified in the drawing(s).
- b) Straightness shall be within 6 mm in 1500 mm to permit shearing.

--0--0--

This document is the property of Bharat Earth Movers Limited, India. It must not be used directly or indirectly in any way detrimental to the interest of company without written consent of the proprietors.

This document is the property of BEML Limited, India. It must not be used, directly or indirectly, in any way detrimental to the interest of Company without written consent of the proprietors.



UNIT STANDARDS

TITLE:
HOT ROLLED LOW ALLOY STEEL MATERIAL
FOR ESS (EXTREME SERVICE SHOES)
TRACK SHOES

AMENDMENT No. 01

DATE: 2019-08-21

STD No. B1202-00

AMENDMENT SHEET - 1/1

ISSUE No. 01

In page No. 2 of 2, clause 6 shall read as follows:

6. SUPPLY CONDITION:

Track shoes shall be supplied in "As Rolled" condition with a hardness of 255 BHN max.

Ref: Mail from AGM(CMRM), dated 27.02.2019.

APPROVED BY:

GE



UNIT STANDARDS KGF COMPLEX-B

B 1202-00

TITLE: HQT ROLLED LOW ALLOY STEEL
MATERIAL FOR ESS (EXTREME-
SERVICE SHOES) TRACK SHOES

PAGE NO.1 OF 2

DATE:1988-04-28

1. SCOPE :

This specification covers hot Rolled Track Shoe stock for
Crawler Tractor in accordance with details given below :

2.1. CHEMICAL COMPOSITION PERCENTAGE :

Carbon	0.28 - 0.33	Sulphur	0.03 Max.
Manganese	1.00 - 1.30	Phosphorous	0.03 Max
Silicon	0.25 - 0.35	Boron	0.0005 - 0.003
Chromium	0.35 - 0.65	Molybdenum	0.08 - 0.15

2.2. ALLOWABLE VARIATION IN CHEMICAL COMPOSITION IN PERCENTAGE :

C	Mn	Si
± 0.01	± 0.04	± 0.02

Chemical analysis shall be performed in accordance with IS:228

NOTE : a) One sample Track Shoe per heat shall be selected at random
and tested for chemical composition. When the Chemical
composition is within allowable limits as specified in
para 2.1; the entire lot with same heat number shall be
accepted. In case the chemical composition is not within
allowable limits as specified in para 2.1, one more Track
shoe will be tested for chemical composition. If the
results of retest for chemical composition is within the
allowable variation (para 2.2); the batch will be
accepted.

POSITION TO EXTRACT SAMPLE FOR CHEMICAL ANALYSIS :

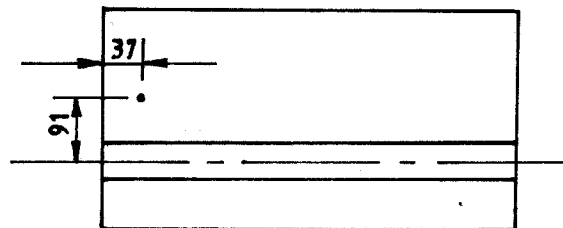

DIMENSIONS IN MM ONLY

The document is the property of Bharat Earth Movers Limited, India. It must not be used directly or indirectly in any way detrimental to the interest of company without written consent of the proprietors.

PREPARED BY:

gsm 88-04-28

ISSUE NO:

NO. OF PLACES: 1

REPLACEMENT FOR:

EM. STANDARD :

01.04.07

01.04.08

REF :

APPROVED BY:

ALTERED BY:



UNIT STANDARDS

KGF COMPLEX-B

B 1202-00 1

TITLE : HOT ROLLED LOW ALLOY STEEL
MATERIAL FOR ESS (EXTREME-
SERVICE SHOES) TRACK SHOES

PAGE NO.2 OF 2

DATE : 1988-04-28

b) If a lot is rejected based on the result of retest for chemical analysis, joint analysis may be made only once, if requested by the supplier. On such occasions one more additional Track Shoe (a third sample) shall be tested, and if the result of joint analysis (on third sample) is within allowable limits as specified in para 2.2 the lot shall be accepted.

3. GRAIN SIZE : ASTM 5 - 8.

4. INCLUSION CONTENT : Test in accordance with IS: 4163.
Requirement : 2 of IS: 4163.

5. HARDENABILITY :

a) Hardenability shall be determined in accordance with IS: 3848

b) Requirement : Distance in mm from Quenched end.

	<u>Distance</u>				<u>Hardness - HRC</u>
△	1.5	:	49-56	:	48 - 55
	5.0	:	39- 50	:	45 - 52
	7.0	:		:	42 - 48

6. SUPPLY CONDITION :

Track Shoe shall be supplied in normalised condition.

7. DIMENSIONAL REQUIREMENT AND TOLERANCES :

The section must conform to the dimensions/tolerances specified in the drawing/drawings (enclosed as per para (9))

Straightness should be within 6 mm in 1500mm to permit sheering.

8. OTHER REQUIREMENTS :

Track Shoes should be free from the following defects.

- | | |
|------------------|---------------------|
| a) Linear Scars | g) Exfoliation |
| b) Exfoliation | h) Jaw Scars |
| c) Die Insertion | i) Laminations |
| d) Jaw Scards | j) Biting |
| e) Roll marks | k) Hair line cracks |
| f) Laminations | |

9. APPLICABILITY OF DRAWINGS :

<u>SL.NO.</u>	<u>EQUIPMENT</u>	<u>PART NO.</u>
1.	D155A-1	125.CT.11001 /1
2.	D355A-3	130.CT.11008 /1

The document is the property of Bharat Earth Movers Limited, India. It must not be used directly or indire. in any way detrimental to the interest of company without written consent of the proprietors.

	PRODUCT SPECIFICATIONS OF ROLLED TRACK SHOE PLATE	
--	--	--

1 SCOPE:

This document regulates specifications of manufacturing, product and inspection of rolled track shoe plate to be delivered.

2 STEEL SPECIFICATIONS:

Steel material is to satisfy specifications defined by N.KES 90.154.1 (Purchase specifications of track shoe steel).

3 MANUFACTURING SPECIFICATIONS:

3.1 Manufacturing process

Conforming to manufacturing process assurance items list to be submitted by manufacturers.

3.2 Manufacturing conditions

Conforming to manufacturers' own standard. Heat treatment conditions are to conform to Table 1.

Table 1

Classifi- cation symbol (1)	Material	Water quenching				Tempering	
		Heat- ing (2) tempera- ture	Reten- tion (3) time	Time before quenching (4)	Quenching water tempera- ture	Heating temperature	Reten- tion (3) tempera- ture
A, B	SMn433-1	Auste- nitizing tempera- ture (Ac3) +30 to 50°C	3 to 10 minutes	Within 70 seconds	40°C and below	400 to 420°C	30 and above
F, G	SMnB-2					380 to 420°C	
H	SMnB430H					210 °C	60 and above
I	SMnCB430H						
J	SHSC-2HM						
K, L, M	SMnB-223H	200 °C	30 and above				

Note (1) Classification symbols correspond to those used in Table 2.

(2) Austenitizing temperature (Ac3) to be calculated by C and Mn contents per each material charge.

Calculation formula to conform to manufacturers' own standard.

(3) Retention time to be based on material temperature.

(4) "Time before quenching" means the time lapse since workpiece discharged from quenching furnace until quenching commenced.

Remark: Heat treatment conditions shown in Table 1 define only the case where in-furnace tempering applied after water quenching is performed. (Materials of SMn433-2, etc., which are induction hardened, are not included.)

4 PRODUCT SPECIFICATION:

4.1 Mechanical properties

Conforming to Table 2. Classification A, B, C, D, E (D80 Heavy-duty) and F not to be used, but K, L and M to be used, although items procured overseas are excluded.

Table 2 (1/2)

Classification symbol		A	B	C	D	E	F	G	H	I	J	
Material		SMn433-1				SMn433-2	SMnB-2		SMnB430II	SMnCB430II	SHSC-2HM	
Heat treatment		WQ+FT		WQ+IT			WQ+FT					
b ⁽¹⁾ (Thickness of main grouser root portion)		29mm and below	30 to 33mm	29mm and below	30 to 33mm	34 to 45mm	33mm and below	34 to 40mm		41 to 52mm		
Applicable model	Heavy-duty	—	—	D60	—	D80	—	—	D155	D355·375·455·475	D355·375·455·475 (option for wearing terrain)	
	Single	D20·30	—	D40·50·60·80	D155	D355C·375C	—	—	—	—	—	
	Double	—	—	—	—	—	—	PC650·1000	—	—	—	
	Semi-double	D20·30	PC400	D40·50·57S PC100·200	D60·75S·80	—	—	—	—	—	—	
	Triple	D20·30·40·50 PC60·75U·80 ·100·120·150	PC400	—	D60·80·95S	—	D57S·75S PC200·220· 300·400	—	—	—	—	
Mechanical properties ⁽²⁾	Surface hardness	Grouser portion (X1)	HRC 38 to 44		HRC 37 to 43		HRC 38 to 44		HRC 43 to 51	HRC 45 to 53		
		Plate portion (X3)			HB 277 to 331							
	Base material hardness	Grouser center (X2)	HRC 32 and above	HRC 28 and above	HRC 32 and above	HRC 28 and above		HRC 32 and above	HRC 20 and above	HRC 40 and above	HRC 35 and above	
		Tensile strength (kg/mm ²)	116 and above		95 and above			116 and above		145 and above		
	Yielding point (kg/mm ²)	99 and above		80 and above			99 and above		120 and above			
	Elongation (%)	10 and above		15 and above			12 and above		10 and above			
	Charpy value (kgm/cm ²)	Grouser portion (L direction)	3 and above					7 and above	4 and above	6 and above		[6.5 and above]
Plate portion (L direction)		3 and above		7 and above			4 and above	—	—	—		
Plate portion (C direction)		—	—	—	—	—	—	—	4 and above		[4.5 and above]	

Table 2 (2/2)

Classification symbol		K	L	M	
Material		SMnB-223H			
Heat treatment		WQ + F T			
b ⁽¹⁾ (Thickness of main grouser root portion)		29mm and below	30 to 33mm	34 to 40mm	
Applicable model	Heavy-duty	D60	—	D80	
	Single	D20·30·40·50·60·80	D155	—	
	Double	—			
	Semi-double	D20·30·40·50·57S PC100·200	D60·75S·80	—	
	Triple	D20·30·40·50·57S PC60·75UJ·80·100· 120·150·200·220	D60·75S·80·95S PC300·400	—	
(2) Mechanical properties	Surface hardness	Grouser portion (X1)	HRC 42 to 49		
		Plate portion (X3)			
	Base material hardness	Grouser center (X2)	HRC 32 and above	HRC 28 and above	HRC 27 and above
		Tensile strength (kg/mm ²)	140 and above		
	Yielding point (kg/mm ²)	120 and above			
	Elongation (%)	15 and above			
	Charpy value (kgm/cm ²)	Grouser portion (L direction)	7 and above		
		Plate portion (L direction)	—		
Plate portion (C direction)		5 and above			

- Remarks
- Mechanical properties to be examined per heat treatment charge.
 - Hardness and tensile test to be performed at rate of N = 1 per charge. Charpy test to be performed at rate of TP = 3 per charge considering measurement fluctuation, and their mean values to satisfy Table 2.
 - Charpy values in brackets are for reference. Official standard values to be determined after studying results of initial 10 charges.

Remarks 4 Tensile test specimen dimensions are to conform to Table 3.

Table 3

Plate thickness t (mm)	Tensile test specimen	Charpy test specimen		
	L direction	L direction		C direction
	Plate portion	Plate portion	Grouser portion	Plate portion
t = 7	JIS No. 14A (D=6mm)	JIS No. 3 sub-size (width 5 mm)	For grouser top of 10 mm or less, use JIS No. 3 sub-size, and for others, use JIS No. 3.	JIS No. 3 sub-size (width 5 mm)
7 < t < 11	JIS No. 14A (D=8mm)	JIS No. 3		JIS No. 3
11 ≤ t < 19			—	
19 ≤ t			JIS No. 3	

Note (1) "b" (thickness of main grouser root portion) to be as following.

Fig. 1

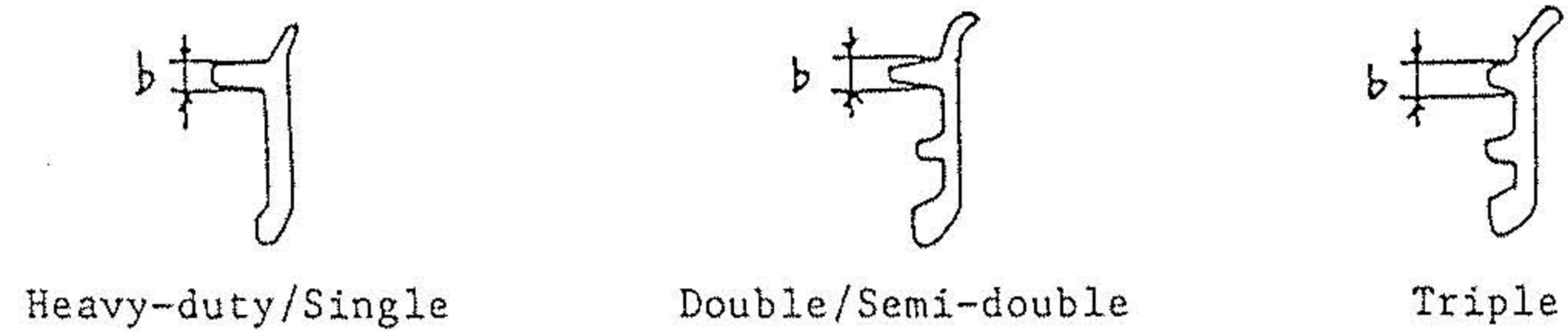

(2) Hardness measuring position and tensile/Charpy test specimen sampling position are to be as follows:

Fig. 2 Hardness measuring position

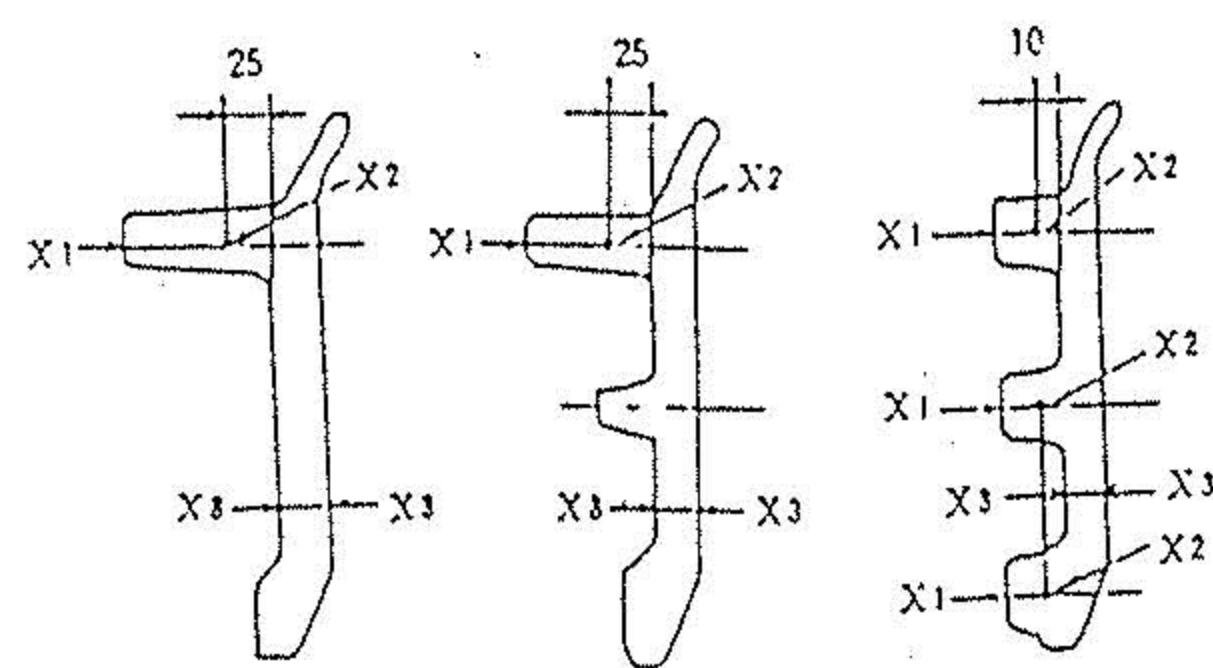

X1, X2 and X3 to be positioned at shoe width center.

Fig. 3 Tensile test specimen sampling position

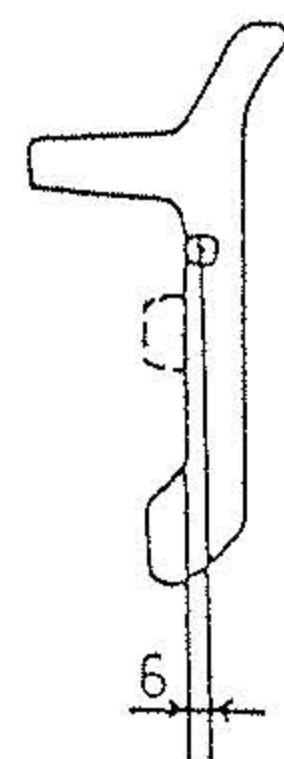

Width direction to be randomly selected.

Fig. 4 Charpy test specimen sampling position

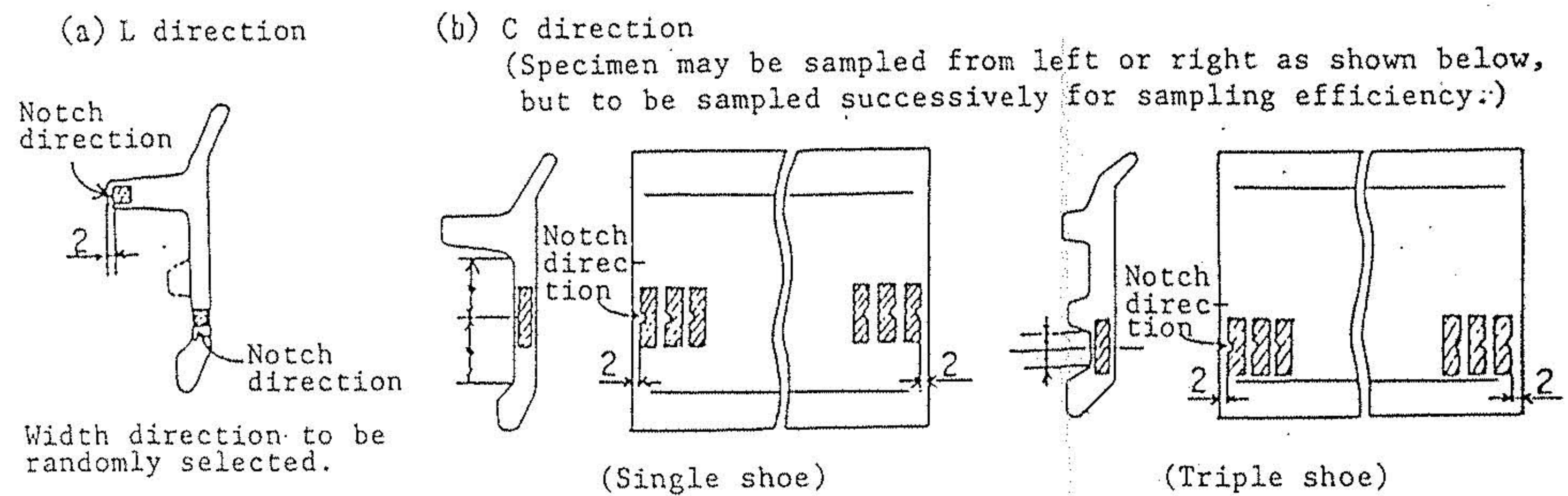

Width direction to be randomly selected.

(Specimen may be sampled from left or right as shown below, but to be sampled successively for sampling efficiency:)

(Single shoe)

(Triple shoe)

4.2 Concaved or convexed shear drop tolerance of main grouser end faces:

This tolerance (values as shown in Fig. 5) of press sheared steel varies according to grouser height (shown in Fig. 6) and to be no more than values of Table 4.

Table 4

Unit: mm

Shoe type	Position	Main grouser height								
		$l \leq 38.5$	$38.5 < l \leq 40$	$40 < l \leq 47.2$	$47.2 < l \leq 48$	$48 < l \leq 50$	$50 < l \leq 55$	$55 < l \leq 61$	$61 < l \leq 65$	$65 < l \leq 72$
Heavy-duty Single	a	1.8	2.2	2.5	2.5	3.0	4.0	4.3		
	b	2.3	3.2	4.4	4.4	5.0	6.4	7.5		
	c	20	27	39	39	47	60	70		
Semi-double	a	2.2	2.5	2.7	2.7	3.3	—			
	b	3.5	4.4	4.5	4.5	5.2	—			
	c	27	39	42	42	50	—			
Triple	a	2.2	—	—	—	—	—	—		
	b	3.2	—	—	—	—	—	—		
	c	27	—	—	—	—	—	—		

Fig. 5

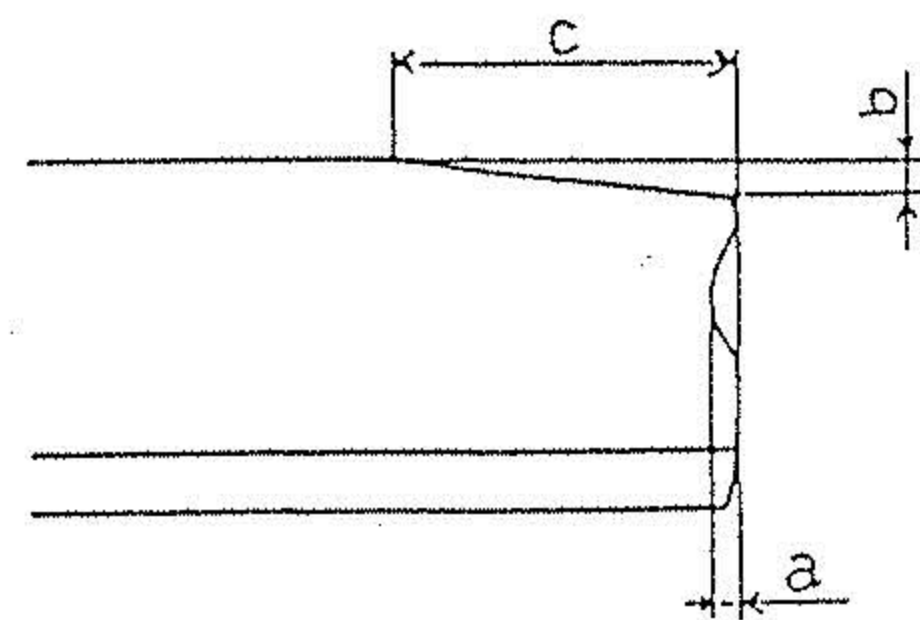
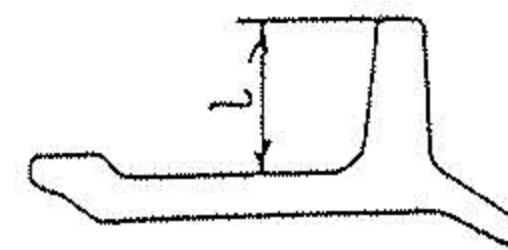

Fig. 6



4.3 Shear drop tolerance of hot punched holes:

Shear drop tolerance of hot punched holes such as shoe bolt holes depend on link pitch P (mm) and is to be no more than values of Table 5.

Table 5

Unit: mm

Position	Link pitch P		
	$P \leq 175$	$190 \leq P \leq 228$	$260 \leq P$
d	0.6	0.8	1.4
e	3	5	8

Fig. 7

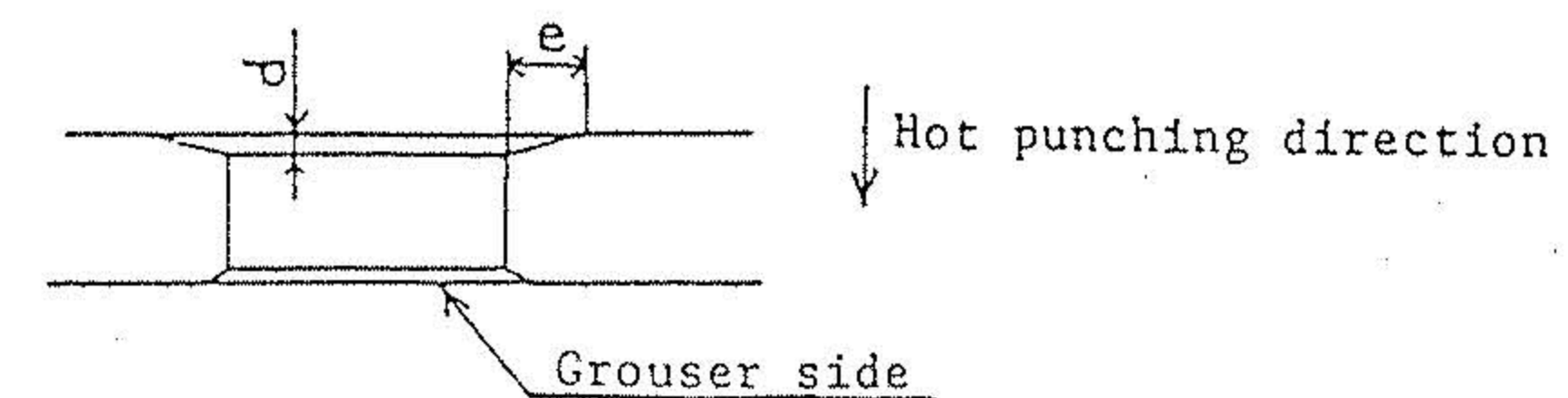

- 4.4 Tolerance of squareness
Tolerance of squareness not specified in drawings is to conform to Table 6.

Table 6

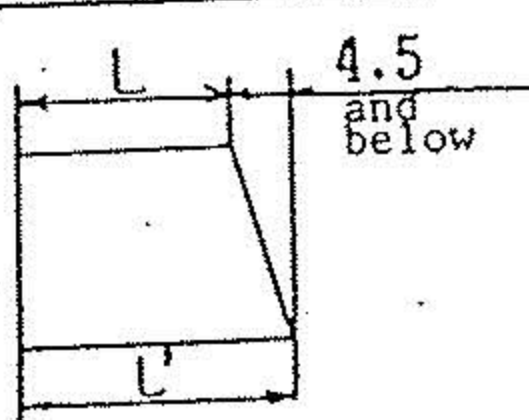
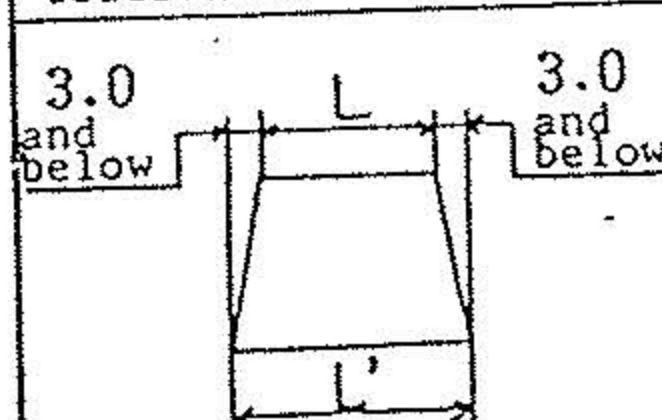
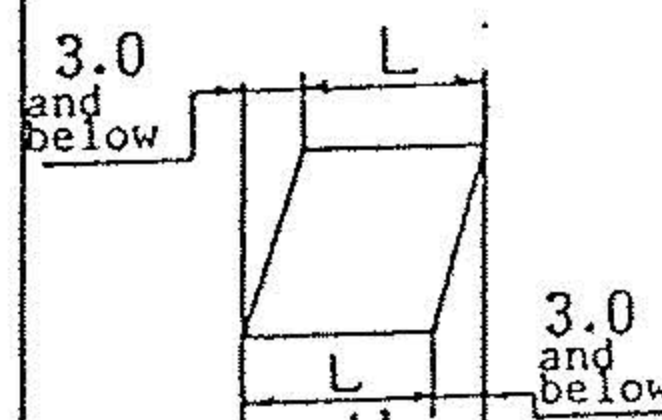
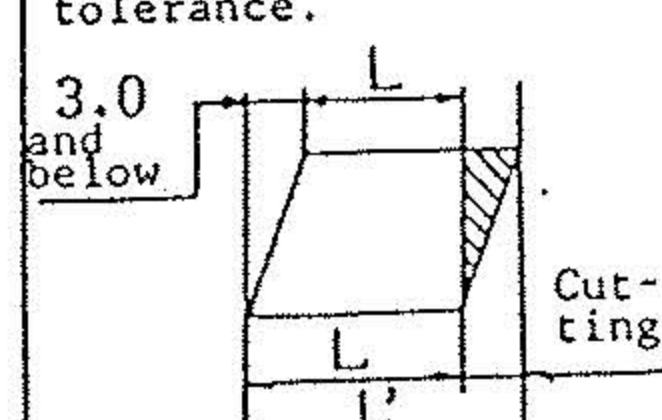
Classification	Tolerance	Measuring tool	Illustrated figure
When one side face is square.	4.5mm and below	Square, taper gauge or vernier caliper	 <p>L & L' to be within tolerance.</p>
When both side faces are not square.	3.0mm and below		 <p>L & L' to be within tolerance.</p>
When both side faces are not square, but cut in parallel.			 <p>L & L' to be within tolerance.</p>
			 <p>L & L' to be within tolerance. L' to be cut when it is out of tolerance.</p>

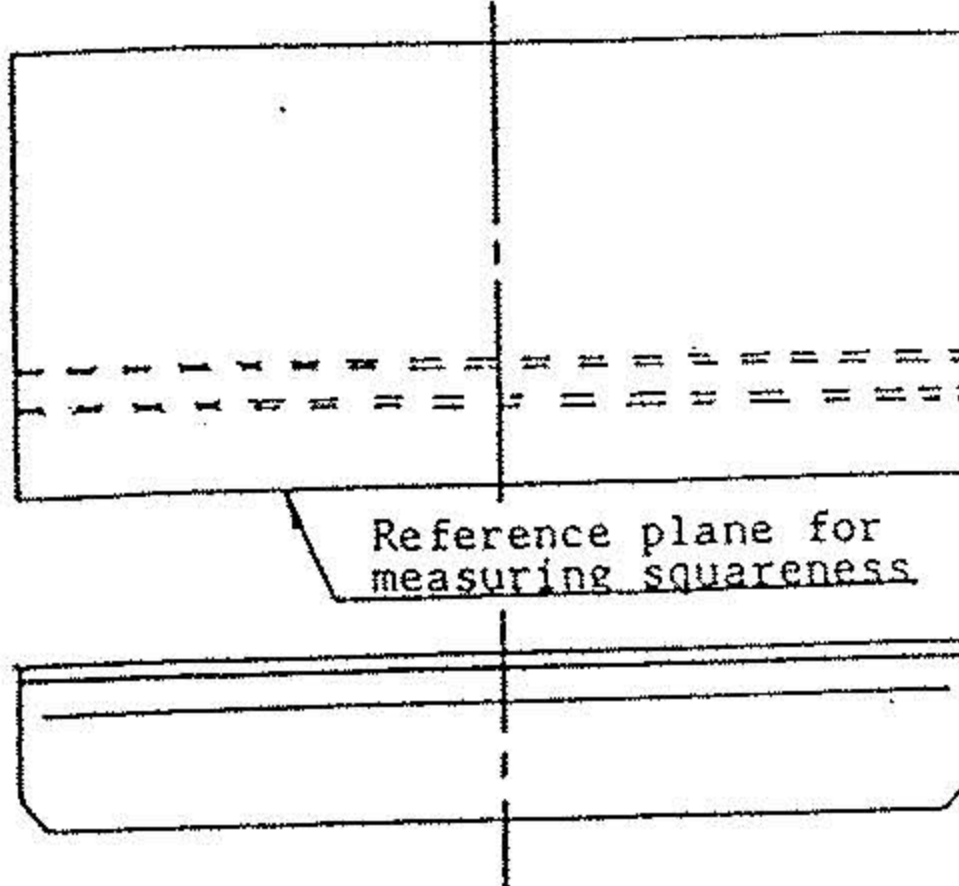

Reference plane for measuring squareness.

- 4.5 Appearance and flaws
- (1) No quenching crack allowed.
 - (2) Limit of flaws other than quenching crack is to conform to attached table.
 - (3) Flaws within dimensional tolerance may be removed.
Flaw removal mark to be smoothly finished with a grinder.

5. RUST PREVENTION:

All surfaces must be coated with equivalent, and no rust to be formed even if left outside for over 10 days. However, the rolled plates with the indication of "no corrosion prevention treatment" shall be delivered separately without corrosion prevention treatment.

Reference: This specification was wholly reconsidered and newly standardized based on N.KES 90.254 (Rolled track shoe plate) and "Purchase specifications of rolled track shoes," No. 150.010.

Attached table (1/2)

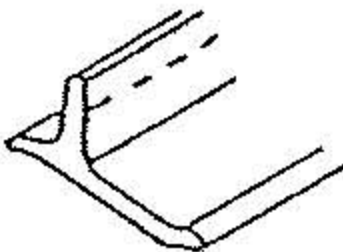
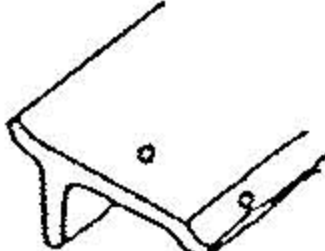
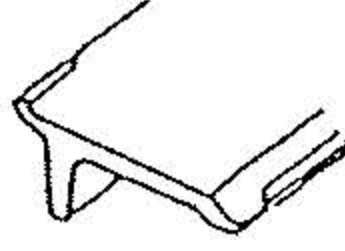
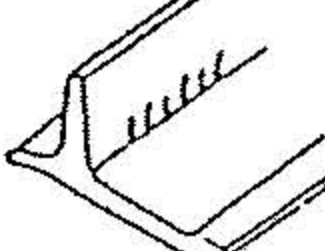
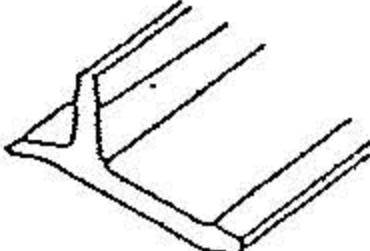
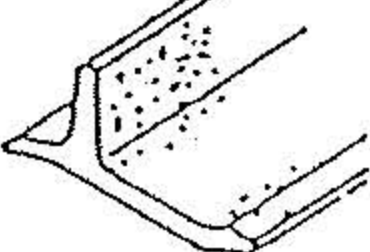
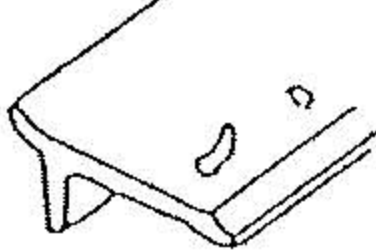
Type of defect	Limit	Inspection method	Illustration
Line cut	Depth: 1.0 mm	Magnetic particle test or visual inspection	
Peeling			
Folding			
Wrinkle			
Roller stain			
Rough surface			
Scale			

Attached table (2/2)

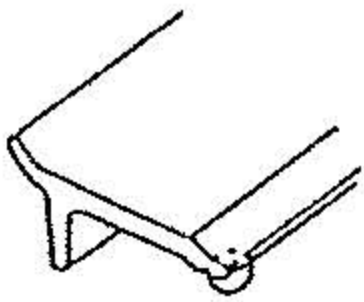
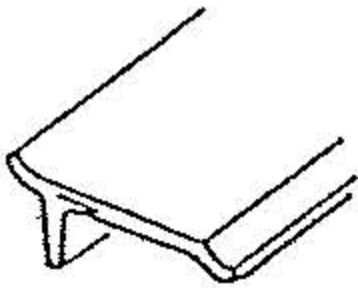
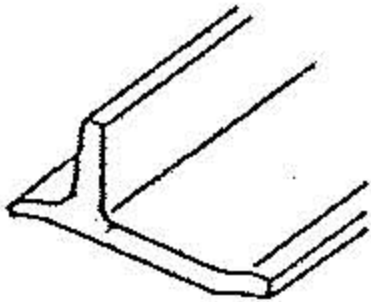
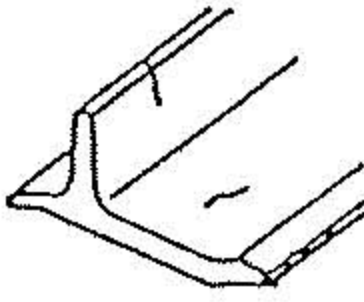
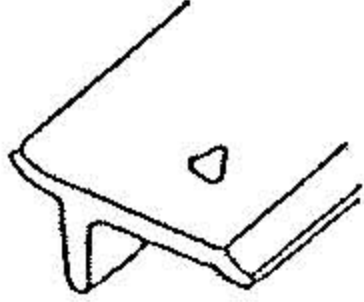
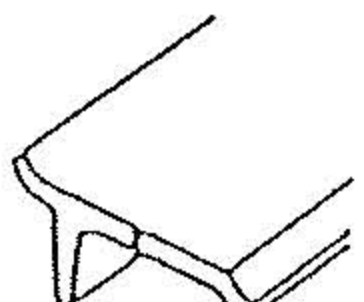
Type of defect	Limit	Inspection method	Illustration
Burr	0.5mm	Visual inspection	
Pipe	Not allowed	Magnetic particle test or visual inspection	
Hair crack	Not allowed on face R		
Lamination	50 mm, one side only	Magnetic particle test	
Brick flaw	Not allowed	Visual inspection	
Cutting flaw	1.0 mm for both depth and width		



बी ई एम एल

beml
NEW FRONTIERS. NEW DREAMS

COMPANY STANDARDS

TITLE:
**RUST PREVENTION BY PROCESS PRIMER
APPLICATION- CODES**

PR1031-C

PAGE No. 1 OF 9

DATE: 2017 - 03-03

0. GENERAL INFORMATION :

- a) This revision supersedes Issue-01 of PR1031-C dated 2007-08-31
- b) This issuance is necessitated by :
The reclassification of codes for Paint and Paint related materials listed in table-1 of company standard C6001 (Paint and Paint related materials).
The colour shade code for Paint / Primer is newly introduced in-line with Indian standard (IS) and RAL standard and listed in table-2 of company standard C6001.
- c) Epoxy based zinc phosphate primer provides good adhesion to substrata, resistance to moisture and superior corrosion resistance characteristics than PU primer. The Epoxy based zinc phosphate primer coating is intended to serve as first undercoat for finish paints and also it is intended to serve as barrier against adhesion of weld spatters because of high zinc content.
- d) The epoxy primer is used as under coat for both
 - i) Epoxy paint top coats and
 - ii) Polyurethane (PU) paint top coat.
- e) In view of the above, BEML painting system is updated to Epoxy primer as undercoat and Polyurethane Finish paint as top coat, in preference to other paints.
- f) The colour shade of the undercoat primer shall match approximate to the top coat colour shade when colour shade is mentioned in the drawing or wherever required. Even though, all the colour shades used in BEML are listed in colour shade table given in company standard C6001, for general practice usage : The preferred colour shade for under coat primer shall be **Middle buff** to colour shade code 359 and designation is C6001-36-359 (Epoxy primer with Middle buff colour shade).

Wherever the parts to be top coated with dark colour shades as indicated in drawing / specific requirement the preferred colour shade for undercoat primer shall be **Dark admiralty gray** to colour shade code 632 and designation is C6001-36-632 (Epoxy primer with **Dark admiralty gray** colour shade) .

1. SCOPE :

This standard defines the codes used in BEML drawings, process sheets to denote the sequence of operations for different categories of components and parts of Construction and Mining equipments for application of primer for in-process corrosion prevention. The primer coating is also intended to serve as barrier against adhesion of weld spatter and as first under coat for finishing top coat.

PREPARED BY : CSD	ISSUE No. : 02	REPLACES: ---	REF : MOM , Ref : GES/21/PAINT/326A Dt.12.06.2015
APPROVED BY :	 G (M&C)	 ED(E)	 D (M&C)

This document is the property of BEML, Limited, India. It must not be used directly or indirectly in any way detrimental to the interest of Company without written consent of the proprietors.



2. APPLICABILITY :

The following codes identify the procedure applicable to the different categories of components and parts. Appropriate codes as indicated in Table-1 shall be referred in part drawings in the surface treatment column.

Table-1, Process codes:

SL NO	CODE	APPLICABILITY
01	PCS	Parts cut or formed from cold rolled steel sheets
02	PHS	Parts cut from hot rolled steel sheets
03	PSP	Parts cut from steel plates
04	PHF	Hot formed parts
05	PCF	Castings & Forgings
06	PST	Structural's, Pipes & Tubes
07	PWP	Welded parts
08	PSW	Stress relieved welded structures
09	PGP	General parts
10	PSC	Parts with special coatings

Designation of code in drawing :

Applicable process code followed by “,” and company standard number to be indicated in Surface treatment column provided.

Example : for Parts cut or formed from cold rolled steel sheets, Epoxy primer application process code as follows:

Primer application Code : PCS, PR1031-C

3. PROCESS CODES AND SEQUENCE OF OPERATIONS FOR APPLICATION OF EPOXY BASED ZINC PHOSPHATE PRIMER (C6001-36) :

3.1 PROCESS CODE - 'PCS':

3.1.1 APPLICABILITY :

This process is applicable to components made from cold rolled sheets. This process also applies to parts cut from cold rolled sheets which have been cold formed to the required shapes.

Note : The individual sheet components shall be free of sharp edges, burrs, dents deep scratches etc. and surfaces shall be clear of oxide and rust films.

3.1.2 PROCESS :

Following is the recommended sequence of operations for assemblies / sub assemblies fabricated from the above sheet components or fully finished component :

3.1.2.1. DEGREASING AND DERUSTING :

Degreasing shall be carried out by any one or combinations of the following (Ref. IS:6049) :

- a) Wire brushing
- b) Chemical derusting (rust remover)
- c) Petroleum solvent (dip or swab)
- d) Ultrasonic cleaning
- e) Emulsion
- f) Steam blasting

3.1.2.2 ZINC PHOSPHATING :

Provide zinc phosphate coating (PZ-M) to a thickness of 10 micrometer min. per sq meter as per company standard PR1008-C as undercoat for Epoxy based Zinc Phosphate Primer.

3.1.2.3 PRIMER COATING :

Apply two coats (each coat of 30 to 40 micrometer DFT) of Epoxy based Zinc Phosphate Primer to company standard C6001-36 to a coating thickness of 60 to 80 micrometer of DFT by spray immediately after degreasing and derusting / phosphating. Allow 10~15 minutes between 1st coat to 2nd coat. Allow the primer coating to dry completely for at least 8 hours.

3.2. PROCESS CODE – ‘PHS’**3.2.1 APPLICABILITY :**

This process is applicable to parts cut from hot rolled sheets.

NOTE : There is possibility of the hot rolled sheets being supplied without adequate blast cleaning and rust / corrosion preventive coating. Therefore the surfaces of the sheets are likely to have mill scale and light rust. Individual components shall be free of these surface defects before being taken up for fabrication of assemblies.

3.2.2 PROCESS :

Following is the recommended sequence of operations for sheet metal components cut from hot rolled sheet :

3.2.2.1 DESCALING AND DERUSTING (Ref. IS : 6049) :

Descaling and derusting of the parts shall be carried out by any one or combination of the following :

- a) Wire brushing
- b) Emerying
- c) Alkali / Acid pickling
- d) Application of rust remover (chemical derusting)

**3.2.2.2 PHOSPHATING :**

Provide zinc phosphate coating (PZ-M) to a thickness of 10 micrometer minimum per sq meter as per Company Standard PR1008-C as undercoat for Epoxy base Zinc Phosphate Primer to Company standard C6001-36.

3.2.2.3 PRIMER COATING :

Apply two coats (each coat of 30 to 40 micrometer DFT) of Epoxy based Zinc Phosphate Primer to company standard C6001-36 to a coating thickness of 60 to 80 micrometer of DFT by spray immediately after degreasing and derusting / phosphating. Allow 10~15 minutes between 1st coat to 2nd coat. Allow the primer coating to dry completely for at least 8 hours.

3.3. PROCESS CODE - 'PSP'**3.3.1 APPLICABILITY :**

This process is applicable to parts cut from hot rolled steel plates.

- 1) If hot rolled steel plates are received without any surface coating for corrosion prevention after hot rolling / normalizing, the surfaces of the plates are likely to have mill scales and light rust. The plates may also have rust due to long storage in house.
- 2) The plates from overseas sources are normally supplied as blast cleaned and coated with corrosion preventive for sea freight. After gas / flame cutting in house, the cut pieces will have light oxide film and damaged surface coating due to gas cutting.

3.3.2 PROCESS :

Following is the recommended sequence of operations :

3.3.2.1 DESCALING AND DERUSTING :

Descaling and derusting of the parts cut from the plates shall be carried out by one or combination of the following :

- a) Shot blasting
- b) Wire brushing (in case of light rust and no scale)
- c) Alkali / Acid picking. (in case of heavy mill scale if shot blasting facility is not available).
- d) Chemical derusting (in case of no mill scale, for light / medium – rust removal).
Rinse with water (with suitable corrosion inhibitor) or with suitable solvent (M.T.O. / Petroleum solvent) for degreasing, if necessary).

3.3.2.2 PRIMER COATING :

Apply two coats (each coat of 30 to 40 micrometer DFT) of Epoxy based Zinc Phosphate Primer to company standard C6001-36 to a coating thickness of 60 to 80 micrometer of DFT by spray immediately after degreasing and derusting / phosphating. Allow 10~15 minutes between 1st coat to 2nd coat. Allow the primer coating to dry completely for at least 8 hours.



3.4 PROCESS CODE – ‘PHF’

3.4.1 APPLICABILITY :

This process is applicable to parts cut from hot-rolled steel plates and hot-formed for obtaining the desired shape.

Some of the hot-formed parts are also heat-treated by normalizing / hardening and tempering etc., to obtain the desired mechanical properties before machining.

3.4.2 PROCESS :

Following is the recommended sequence of operations :

3.4.2.1 DESCALING AND DERUSTING :

Descaling and derusting of the hot-formed parts shall be carried out by blast cleaning preferably by shot blasting. Where shot blasting is not feasible, alkali / acid pickling may be resorted to clean the surface by using clean and dry compressed air after shot blasting or clean with suitable solvent (by swabbing with cotton cloth soaked in the solvent) to remove the surface contaminants.

3.4.2.2 PRIMER COATING :

Apply two coats (each coat of 30 to 40 micrometer DFT) of Epoxy based Zinc Phosphate Primer to company standard C6001-36 to a coating thickness of 60 to 80 micrometer of DFT by spray immediately after degreasing and derusting / phosphating. Allow 10-15 minutes between 1st coat to 2nd coat. Allow the primer coating to dry completely for at least 8 hours.

3.5. PROCESS CODE – ‘PCF’ :

3.5.1 APPLICABILITY :

This process code pertains to castings and forgings.

For supply conditions of castings and forgings, refer Company Standard PR1029-C, in which process primer application is specified wherever applicable. In addition to this, the applicable procedure for castings and forgings which need to be painted after heat treatment is as follows :

- a) Blast cleaning – As required.
- b) Apply two coats (each coat of 30 to 40 micrometer DFT) of Epoxy based Zinc Phosphate Primer to company standard C6001-36 to a coating thickness of 60 to 80 micrometer of DFT by spray immediately after degreasing and derusting / phosphating. Allow 30 minutes between 1st coat to 2nd coat. Allow the primer coating to dry completely for at least 8 hours.
- c) Corrosion preventive coating on other surfaces and on machine surfaces as required.

NOTE : The requirements in regard to blast cleaning and application of suitable corrosion / rust preventive to be used shall be as specified in the applicable process sheet.



TITLE :

RUST PREVENTION BY PROCESS PRIMER
APPLICATION- CODES

PAGE No. 6 OF 9

DATE: 2017 -03 -03

3.6 PROCESS CODE - 'PST' :**3.6.1 APPLICABILITY :**

This process code is applicable to structurals such as angles, channels, beams, bars, tubes & pipes etc., used for fabricated structures.

Wherever the Pipes / Tubes are used for Hydraulic application, Zinc Phosphating is compulsory and Phosphating process shall be conducted as per PR1031-C. The Zinc Phosphating codes shall to be indicated additionally in the drawing / wherever required.

3.6.2 PROCESS :

Following is the recommended sequence of operations :

3.6.2.1 DESCALING AND DERUSTING :

Descaling and derusting of the parts shall be carried out by one or combination of the following :

- a) Shot blasting.
- b) Wire brushing (In case of light rust and no scale)
- c) Alkali / Acid pickling (in case of heavy mill scale if shot blasting facility is not available).
- d) Chemical derusting (In case of no mill scale, for light / medium – rust removal). Rinse with water (with suitable corrosion inhibitor) or with suitable solvent (M.T.O. / Petroleum solvent) for degreasing, if necessary.

3.6.2.2 PHOSPHATING : (Applicable for the structurals, tubes & pipes used for Hydraulic application).

Provide zinc phosphate coating (PZ-M / PZ-H) suitable for application as per company standard PR1008-C as undercoat for Epoxy base Zinc Phosphate Primer.

3.6.2.3 PRIMER COATING :

Apply two coats (each coat of 30 to 40 micrometer DFT) of Epoxy based Zinc Phosphate Primer to company standard C6001-36 to a coating thickness of 60 to 80 micrometer of DFT by spray immediately after degreasing and derusting / phosphating. Allow 10-15 minutes between 1st coat to 2nd coat. Allow the primer coating to dry completely for at least 8 hours.

3.7 PROCESS CODE -- 'PWP' :**3.7.1 APPLICABILITY :**

This process is applicable to welded parts which do not undergo thermal stress relieving. Components of the welded parts should have been provided with Epoxy based Zinc phosphate primer to Company Standard C6001-36 before welding.

This document is the property of BEML Limited, India. It must not be used directly or indirectly in any way detrimental to the interest of Company without written consent of the proprietors.

3.7.2 PROCESS :

Following is the recommended sequence of operations :

3.7.2.1 REMOVAL OF SPATTER :

Adherent welding spatter shall be removed by wire brushing, chipping and /or hand grinding immediately after welding.

3.7.2.2 The earlier process primer coating removed or damaged during welding, spatter removal and handling needs to be touched up by brushing.

3.8. PROCESS CODE - 'PSW' :**3.8.1 APPLICABILITY :**

This process is applicable to thermally stress relieved welded structures made of steel plates, castings and structurals.

The detail parts used in the fabricated structure are expected to have been surface cleaned and provided with process primer coating before fabrication. The epoxy based zinc phosphate primer coating gets damaged during thermal stress relief and needs to be replaced. The weld spatters adherent on the surface adjacent to the welds (despite epoxy based zinc phosphate primer coating and / or anti spatter spray used, if any) needs to be removed by chipping and hand grinding.

3.8.2 PROCESS :

Following is the recommended sequence of operations :

3.8.2.1 REMOVAL OF SPATTER :

Adherent welding spatter shall be removed by wire brushing, chipping and / or hand grinding immediately after welding.

3.8.2.2 BLAST CLEANING :

The initial epoxy based zinc phosphate primer / rust preventive coatings applied prior to fabrication and thermal stress relief shall be removed by grit blasting or light shot blasting. After blast cleaning the surfaces shall be cleaned with clean dry compressed air.

3.8.2.3 SURFACE PREPARATION :

Surface contaminants such as adherent dust, oil / grease – films, if any shall be removed by wiping with cotton cloth soaked in M.T.O / petroleum solvent.

3.8.2.4 PRIMER APPLICATION :

To the surfaces prepared as above, apply two coats (each coat of 30 to 40 micrometer DFT) of Epoxy based zinc phosphate primer to Company Standard C6001-36 to thickness of 60 to 80 micrometer DFT by spray. Allow 10~15 minutes between 1st coat to 2nd coat. Allow the coating to dry completely (at least 8 hours) before further processing.

NOTE : Wherever thermal stress relieving is needed, the same must be mentioned as a note in the drawing.



3.9 PROCESS CODE - 'PGP' :

3.9.1 APPLICABILITY :

This process code is applicable to general parts not covered by any of the above processes machined components and welded parts which require a part of their machined / un machined surfaces to be painted also fall in to this category.

3.9.2 PROCESS :

Following is the recommended sequence of operations.

3.9.2.1 CLEANING AS REQUIRED :

Following are the options available :

- a) Rinse to remove dirt and dust on surface.
- b) Degrease by vapour or by dipping in a suitable solvent. Use recommended solvent to remove temporary rust preventive coating, if any.
- c) In case of rust, use chemical derusting (rust remover) : protect machined surfaces by masking.
- d) Blast cleaning.

3.9.2.2 ZINC PHOSPHATING, IF SPECIFIED :

Provide zinc phosphate coating (PZ-M) to a thickness of 10 micrometer minimum per sq meter as per Company Standard PR1008-C as undercoat for Epoxy base Zinc Phosphate Primer to Company standard C6001-36.

3.9.2.3. PRIMER COATING :

Apply two coats (each coat of 30 to 40 micrometer DFT) of Epoxy based Zinc Phosphate Primer to company standard C6001-36 to a coating thickness of 60 to 80 micrometer of DFT by spray immediately after degreasing and derusting / phosphating. Allow 10~15 minutes between 1st coat to 2nd coat. Allow the primer coating to dry completely for at least 8 hours.

Note : Surfaces not to be primed shall be masked suitably.

This document is the property of BEML Limited, India. It must not be used directly or indirectly in any way detrimental to the interest of Company without written consent of the proprietors.

**3.10.0 PROCESS CODE - 'PSC' :****3.10.1 APPLICABILITY :**

This process is applicable to parts with special purpose coatings, metallic or non metallic, functional or decorative.

Many parts which have been provided with metallic coating (such as hard chrome plating, galvanizing etc.,) or non metallic coatings (powder coatings, special purpose paints) may require a part of their surfaces to be primed for subsequent application of finish paint.

3.10.2.1 PROCESS :

Following is the recommended sequence of operations:

3.10.2.2 CLEANING AS REQUIRED :

Cleaning to remove surface contaminants, so as not to damage the existing special purpose coating, by any one or combination of the following :

- a) Water rinse
- b) Degreasing by application (dipping / swabbing) of suitable solvent.
- c) Ultrasonic cleaning
- d) Application of detergent
- e) Chemical derusting

3.10.2.3 PRIMER APPLICATION :

Apply two coats (each coat of 30 to 40 micrometer DFT) of Epoxy based Zinc Phosphate Primer to company standard C6001-36 to a coating thickness of 60 to 80 micrometer of DFT by spray immediately after degreasing and derusting / phosphating. Allow 10~15minutes between 1st coat to 2nd coat. Allow the primer coating to dry completely for at least 8 hours.

NOTE :

- 1) Shot blasting is preferred to sand blasting in regard to surface finish and health safety. However, blast cleaning is not recommended where thin sections are used.
- 2) Use rust preventives and corrosion inhibitors as per applicable process standards and shop practice in co-ordination with process planning department.
- 3) Latest Issuances of the cited standards shall be referred.

- oOo -

F.No.6/18/2019-PPD
Ministry of Finance
Department of Expenditure
Public Procurement Division

161, North Block,
New Delhi
23rd July, 2020

Office Memorandum

Subject: Insertion of Rule 144 (xi) in the General Financial Rules (GFRs), 2017

Rule 144 of the General Financial Rules 2017 entitled 'Fundamental principles of public buying', has been amended by inserting sub-rule (xi) as under:

Notwithstanding anything contained in these Rules, Department of Expenditure may, by order in writing, impose restrictions, including prior registration and/or screening, on procurement from bidders from a country or countries, or a class of countries, on grounds of defence of India, or matters directly or indirectly related thereto including national security; no procurement shall be made in violation of such restrictions.

(Sanjay Prasad)
Joint Secretary (PPD)
Email ID: js.pfc2.doe@gov.in
Telephone: 011-23093882

To,
(1) Secretaries of All Ministries/ Departments of Government of India
(2) Chief Secretaries/ Administrators of Union Territories/ National Capital Territory of Delhi

F.No.6/18/2019-PPD
Ministry of Finance
Department of Expenditure
Public Procurement Division

161, North Block,
New Delhi
23rd July, 2020

Order (Public Procurement No. 1)

Subject: Restrictions under Rule 144 (xi) of the General Financial Rules (GFRs), 2017

Attention is invited to this office OM no. 6/18/2019-PPD dated 23rd July 2020 inserting Rule 144 (xi) in GFRs 2017. In this regard, the following is hereby ordered under Rule 144 (xi) on the grounds stated therein:

Requirement of registration

1. Any bidder from a country which shares a land border with India will be eligible to bid in any procurement whether of goods, services (including consultancy services and non-consultancy services) or works (including turnkey projects) only if the bidder is registered with the Competent Authority, specified in **Annex I**.
2. This Order shall not apply to (i) cases where orders have been placed or contract has been concluded or letter/notice of award/ acceptance (LoA) has been issued on or before the date of this order; and (ii) cases falling under **Annex II**.

Transitional cases

3. Tenders where no contract has been concluded or no LoA has been issued so far shall be handled in the following manner: -
 - a) *In tenders which are yet to be opened, or where evaluation of technical bid or the first exclusionary qualificatory stage (i.e. the first stage at which the qualifications of tenderers are evaluated and unqualified bidders are excluded) has not been completed:* No contracts shall be placed on bidders from such countries. Tenders received from bidders from such countries shall be dealt with as if they are non-compliant with the tender conditions and the tender shall be processed accordingly.
 - b) *If the tendering process has crossed the first exclusionary qualificatory stage:* If the qualified bidders include bidders from such countries, the

entire process shall be scrapped and initiated *de novo*. The *de novo* process shall adhere to the conditions prescribed in this Order.

- c) As far as practicable, and in cases of doubt about whether a bidder falls under paragraph 1, a certificate shall be obtained from the bidder whose bid is proposed to be considered or accepted, in terms of paras 8, 9 and 10 read with para 1 of this Order.

Incorporation in tender conditions

4. In tenders to be issued after the date of this order, the provisions of paragraph 1 and of other relevant provisions of this Order shall be incorporated in the tender conditions.

Applicability

5. Apart from Ministries / Departments, attached and subordinate bodies, notwithstanding anything contained in Rule 1 of the GFRs 2017, this Order shall also be applicable
 - a. to all Autonomous Bodies;
 - b. to public sector banks and public sector financial institutions; and
 - c. subject to any orders of the Department of Public Enterprises, to all Central Public Sector Enterprises; and
 - d. to procurement in Public Private Partnership projects receiving financial support from the Government or public sector enterprises/ undertakings.
 - e. Union Territories, National Capital Territory of Delhi and all agencies/ undertakings thereof

Definitions

6. "Bidder" for the purpose of this Order (including the term 'tenderer', 'consultant' 'vendor' or 'service provider' in certain contexts) means any person or firm or company, including any member of a consortium or joint venture (that is an association of several persons, or firms or companies), every artificial juridical person not falling in any of the descriptions of bidders stated hereinbefore, including any agency, branch or office controlled by such person, participating in a procurement process.
7. "Tender" for the purpose of this Order will include other forms of procurement, except where the context requires otherwise.
8. "Bidder from a country which shares a land border with India" for the purpose of this Order means

- a) An entity incorporated, established or registered in such a country; or
- b) A subsidiary of an entity incorporated, established or registered in such a country; or
- c) An entity substantially controlled through entities incorporated, established or registered in such a country; or
- d) An entity whose *beneficial owner* is situated in such a country; or
- e) An Indian (or other) agent of such an entity; or
- f) A natural person who is a citizen of such a country; or
- g) A consortium or joint venture where any member of the consortium or joint venture falls under any of the above

9. "Beneficial owner" for the purpose of paragraph 8 above will be as under:

- (i) In case of a company or Limited Liability Partnership, the beneficial owner is the natural person(s), who, whether acting alone or together, or through one or more juridical person(s), has a controlling ownership interest or who exercises control through other means.

Explanation—

- a. "Controlling ownership interest" means ownership of, or entitlement to, more than twenty-five per cent of shares or capital or profits of the company;
 - b. "Control" shall include the right to appoint the majority of the directors or to control the management or policy decisions, including by virtue of their shareholding or management rights or shareholders agreements or voting agreements;
- (ii) In case of a partnership firm, the beneficial owner is the natural person(s) who, whether acting alone or together, or through one or more juridical person, has ownership of entitlement to more than fifteen percent of capital or profits of the partnership;
 - (iii) In case of an unincorporated association or body of individuals, the beneficial owner is the natural person(s), who, whether acting alone or together, or through one or more juridical person, has ownership of or entitlement to more than fifteen percent of the property or capital or profits of such association or body of individuals;
 - (iv) Where no natural person is identified under (i) or (ii) or (iii) above, the beneficial owner is the relevant natural person who holds the position of senior managing official;

4/12

(v) In case of a trust, the identification of beneficial owner(s) shall include identification of the author of the trust, the trustee, the beneficiaries with fifteen percent or more interest in the trust and any other natural person exercising ultimate effective control over the trust through a chain of control or ownership.

10. "Agent" for the purpose of this Order is a person employed to do any act for another, or to represent another in dealings with third persons.

Sub-contracting in works contracts

11. In works contracts, including turnkey contracts, contractors shall not be allowed to sub-contract works to any contractor from a country which shares a land border with India unless such contractor is registered with the Competent Authority. The definition of "contractor from a country which shares a land border with India" shall be as in paragraph 8 above. This shall not apply to sub-contracts already awarded on or before the date of this Order.

Certificate regarding compliance

12. A certificate shall be taken from bidders in the tender documents regarding their compliance with this Order. If such certificate given by a bidder whose bid is accepted is found to be false, this would be a ground for immediate termination and further legal action in accordance with law.

Validity of registration

13. In respect of tenders, registration should be valid at the time of submission of bids and at the time of acceptance of bids. In respect of supply otherwise than by tender, registration should be valid at the time of placement of order. If the bidder was validly registered at the time of acceptance / placement of order, registration shall not be a relevant consideration during contract execution.

Government E-Marketplace

14. The Government E-Marketplace shall, as soon as possible, require all vendors/ bidders registered with GeM to give a certificate regarding compliance with this Order, and after the date fixed by it, shall remove non-compliant entities from GeM unless/ until they are registered in accordance with this Order.

5/12

Model Clauses/ Certificates

15. Model Clauses and Model Certificates which may be inserted in tenders / obtained from Bidders are enclosed as **Annex III**. While adhering to the substance of the Order, procuring entities are free to appropriately modify the wording of these clauses based on their past experience, local needs etc. without making any reference to this Department.

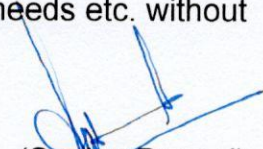
(Sanjay Prasad)
Joint Secretary (PPD)
Email ID: js.pfc2.doe@gov.in
Telephone: 011-23093882

To

- (1) Secretaries of All Ministries/ Departments of Government of India for information and necessary action. They are also requested to inform these provisions to all procuring entities.
- (2) Secretary, Department of Public Enterprises with a request to immediately reiterate these orders in respect of Public Enterprises.
- (3) Secretary DPIIT with a request to initiate action as provided under Annex I
- (4) Chief Secretaries/ Administrators of Union Territories/ National Capital Territory of Delhi

6/12

Annex I: Competent Authority and Procedure for Registration

- A. The Competent Authority for the purpose of registration under this Order shall be the Registration Committee constituted by the Department for Promotion of Industry and Internal Trade (DPIIT)*.
- B. The Registration Committee shall have the following members*:
- i. An officer, not below the rank of Joint Secretary, designated for this purpose by DPIIT, who shall be the Chairman;
 - ii. Officers (ordinarily not below the rank of Joint Secretary) representing the Ministry of Home Affairs, Ministry of External Affairs, and of those Departments whose sectors are covered by applications under consideration;
 - iii. Any other officer whose presence is deemed necessary by the Chairman of the Committee.
- C. DPIIT shall lay down the method of application, format etc. for such bidders as stated in para 1 of this Order.
- D. On receipt of an application seeking registration from a bidder from a country covered by para 1 of this Order, the Competent Authority shall first seek political and security clearances from the Ministry of External Affairs and Ministry of Home Affairs, as per guidelines issued from time to time. Registration shall not be given unless political and security clearance have both been received.
- E. The Ministry of External Affairs and Ministry of Home Affairs may issue guidelines for internal use regarding the procedure for scrutiny of such applications by them.
- F. The decision of the Competent Authority, to register such bidder may be for all kinds of tenders or for a specified type(s) of goods or services, and may be for a specified or unspecified duration of time, as deemed fit. The decision of the Competent Authority shall be final.
- G. Registration shall not be granted unless the representatives of the Ministries of Home Affairs and External Affairs on the Committee concur*.
- H. Registration granted by the Competent Authority of the Government of India shall be valid not only for procurement by Central Government and its agencies/ public enterprises etc. but **also for procurement by State Governments and their agencies/ public enterprises etc. No fresh registration at the State level shall be required.**

7/12

- I. The Competent Authority is empowered to cancel the registration already granted if it determines that there is sufficient cause. Such cancellation by itself, however, will not affect the execution of contracts already awarded. Pending cancellation, it may also suspend the registration of a bidder, and the bidder shall not be eligible to bid in any further tenders during the period of suspension.
- J. For national security reasons, the Competent Authority shall not be required to give reasons for rejection / cancellation of registration of a bidder.
- K. In transitional cases falling under para 3 of this Order, where it is felt that it will not be practicable to exclude bidders from a country which shares a land border with India, a reference seeking permission to consider such bidders shall be made by the procuring entity to the Competent Authority, giving full information and detailed reasons. The Competent Authority shall decide whether such bidders may be considered, and if so shall follow the procedure laid down in the above paras.
- L. Periodic reports on the acceptance/ refusal of registration during the preceding period may be required to be sent to the Cabinet Secretariat. Details will be issued separately in due course by DPIIT.

[*Note:

- i. In respect of application of this Order to procurement by/ under State Governments, all functions assigned to DPIIT shall be carried out by the State Government concerned through a specific department or authority designated by it. The composition of the Registration Committee shall be as decided by the State Government and paragraph G above shall not apply. However, the requirement of **political and security clearance as per para D shall remain and no registration shall be granted without such clearance.**
- ii. Registration granted by State Governments shall be valid only for procurement by the State Government and its agencies/ public enterprises etc. and shall not be valid for procurement in other states or by the Government of India and their agencies/ public enterprises etc.]

8/12

Annex II: Special Cases

- A. Till 31st December 2020, procurement of medical supplies directly related to containment of the Covid-19 pandemic shall be exempt from the provisions of this Order.
- B. *Bona fide* procurements made through GeM without knowing the country of the bidder till the date fixed by GeM for this purpose, shall not be invalidated by this Order.
- C. *Bona fide* small procurements, made without knowing the country of the bidder, shall not be invalidated by this Order.
- D. In projects which receive international funding with the approval of the Department of Economic Affairs (DEA), Ministry of Finance, the procurement guidelines applicable to the project shall normally be followed, notwithstanding anything contained in this Order and without reference to the Competent Authority. Exceptions to this shall be decided in consultation with DEA.
- E. This Order shall not apply to procurement by Indian missions and by offices of government agencies/ undertakings located outside India.

9/12

Annex III

Model Clause /Certificate to be inserted in tenders etc.

(While adhering to the substance of the Order, procuring entities and GeM are free to appropriately modify the wording of the clause/ certificate based on their past experience, local needs etc.)

Model Clauses for Tenders

- I. Any bidder from a country which shares a land border with India will be eligible to bid in this tender only if the bidder is registered with the Competent Authority.
- II. "Bidder" (including the term 'tenderer', 'consultant' or 'service provider' in certain contexts) means any person or firm or company, including any member of a consortium or joint venture (that is an association of several persons, or firms or companies), every artificial juridical person not falling in any of the descriptions of bidders stated hereinbefore, including any agency branch or office controlled by such person, participating in a procurement process.
- III. "Bidder from a country which shares a land border with India" for the purpose of this Order means: -
 - a. An entity incorporated, established or registered in such a country; or
 - b. A subsidiary of an entity incorporated, established or registered in such a country; or
 - c. An entity substantially controlled through entities incorporated, established or registered in such a country; or
 - d. An entity whose *beneficial owner* is situated in such a country; or
 - e. An Indian (or other) agent of such an entity; or
 - f. A natural person who is a citizen of such a country; or
 - g. A consortium or joint venture where any member of the consortium or joint venture falls under any of the above
- IV. The *beneficial owner* for the purpose of (iii) above will be as under:
 1. In case of a company or Limited Liability Partnership, the beneficial owner is the natural person(s), who, whether acting alone or together, or through one or more juridical person, has a controlling ownership interest or who exercises control through other means.

Explanation—

 - a. "Controlling ownership interest" means ownership of or entitlement to more than twenty-five per cent. of shares or capital or profits of the company;

10/12

- b. "Control" shall include the right to appoint majority of the directors or to control the management or policy decisions including by virtue of their shareholding or management rights or shareholders agreements or voting agreements;
2. In case of a partnership firm, the beneficial owner is the natural person(s) who, whether acting alone or together, or through one or more juridical person, has ownership of entitlement to more than fifteen percent of capital or profits of the partnership;
 3. In case of an unincorporated association or body of individuals, the beneficial owner is the natural person(s), who, whether acting alone or together, or through one or more juridical person, has ownership of or entitlement to more than fifteen percent of the property or capital or profits of such association or body of individuals;
 4. Where no natural person is identified under (1) or (2) or (3) above, the beneficial owner is the relevant natural person who holds the position of senior managing official;
 5. In case of a trust, the identification of beneficial owner(s) shall include identification of the author of the trust, the trustee, the beneficiaries with fifteen percent or more interest in the trust and any other natural person exercising ultimate effective control over the trust through a chain of control or ownership.
- V. An Agent is a person employed to do any act for another, or to represent another in dealings with third person.
- VI. *[To be inserted in tenders for Works contracts, including Turnkey contracts]* The successful bidder shall not be allowed to sub-contract works to any contractor from a country which shares a land border with India unless such contractor is registered with the Competent Authority.

Model Certificate for Tenders (for transitional cases as stated in para 3 of this Order)

"I have read the clause regarding restrictions on procurement from a bidder of a country which shares a land border with India; I hereby certify that this bidder is not from such a country and is eligible to be considered."

Model Certificate for Tenders

"I have read the clause regarding restrictions on procurement from a bidder of a country which shares a land border with India; I certify that this bidder is not from such a country or, if from such a country, has been registered with the

11/12

Competent Authority. I hereby certify that this bidder fulfills all requirements in this regard and is eligible to be considered. [Where applicable, evidence of valid registration by the Competent Authority shall be attached.]”

Model Certificate for Tenders for Works involving possibility of sub-contracting

“I have read the clause regarding restrictions on procurement from a bidder of a country which shares a land border with India and on sub-contracting to contractors from such countries; I certify that this bidder is not from such a country or, if from such a country, has been registered with the Competent Authority and will not sub-contract any work to a contractor from such countries unless such contractor is registered with the Competent Authority. I hereby certify that this bidder fulfills all requirements in this regard and is eligible to be considered. [Where applicable, evidence of valid registration by the Competent Authority shall be attached.]”

Model Certificate for GeM:

“I have read the clause regarding restrictions on procurement from a bidder of a country which shares a land border with India; I certify that this vendor/ bidder is not from such a country or, if from such a country, has been registered with the Competent Authority. I hereby certify that this vendor/ bidder fulfills all requirements in this regard and is eligible to be considered for procurement on GeM. [Where applicable, evidence of valid registration by the Competent Authority shall be attached.]”

12/12

Annexure III

Compliance certificate

Bidders having beneficial ownership in countries which share land border with India

- I. Any bidder from a country which shares a land border with India will be eligible to bid in this tender only if the bidder is registered with the competent Authority.
- II. “ Bidder “ (including the term ‘ tenderer ‘ , consultant ‘ or service provider ‘ in certain contexts) means any person or firm or company , including any member of a consortium or joint venture (that is an association of several persons, or firms or companies) every artificial juridical person not falling in any of the descriptions of bidders stated here in before , including any agency branch or office controlled by such person , participating in a process.
- III. “Bidder from a country which shares a land border with India “ for the purpose of this order means : -
 - a. An entity incorporated , established or registered in such country ;or
 - b. A subsidiary of an entity incorporated, established or registered in such a country ;or
 - c. An entity substantially controlled through entities incorporated, established or registered in such a country ; or
 - d. An entity whose beneficial owner is situated in such a country ; or
 - e. An Indian (or other) agent of such an entity ; or
 - f. A natural person who is a citizen of such a country ; or
 - g. A consortium or joint venture where any member of the consortium or joint venture falls under any of the above.
- IV. The beneficial owner for the purpose of (iii) above will be as under :
 1. In case of a company or Limited Liability Partnership, the beneficial owner is the natural person(s) , who , whether acting alone or together , or through one or more juridical person, has a controlling ownership interest or who exercises control through other means.
 - a. “ Controlling ownership interest “ means ownership of or entitlement to more than twenty-five per cent of shares or capital or profits of the company
 - b. “ Control “ shall include the right to appoint majority of the directors or to control the management or policy decisions including by virtue of their shareholding or management rights or shareholders agreement s or voting agreements;
 2. In case of a partnership firm , the beneficial owner is the natural person(s) who , whether acting alone or together , or through one or more juridical person, has ownership of entitlement to more than fifteen percent of capital or profits of the partnership;
 3. In case of an unincorporated association or body of individuals, the beneficial owner is the natural person(s), who , whether acting alone or together , or through one or more juridical person , has ownership of or entitlement to more than fifteen percent of the property or capital or profits of such association or body of individuals;

4. Where no natural person is identified under (1) or (2) or (3) above, the beneficial owner is the relevant natural person who holds the position of senior managing official.
5. In case of a trust , the identification of beneficial owner(s) shall include identification of the author of the trust , the trustee , the beneficiaries with fifteen percent or more interest in the trust an any other natural person exercising ultimate effective control over the trust through a chain of control or ownership.

V An agent is a person employed to do any act for another, or to represent another in dealings with third person.

VI The successful bidder shall not be allowed to sub-contract works to any contractor from a country which shares a land border with India unless such contractor is registered with the competent Authority.

I/we have read the clause regarding above terms and conditions regarding restrictions on procurement whether goods, services (including consultancy service and non consultancy services) or works (including turn key projects)

I / We M/s(Name of the bidder) are not from a country which shares land border with India and as per the above terms and conditions are eligible to participate in this tender.

Or

I / We M/sare from a country which shares land border with India and as per the above terms and conditions ,we are registered with Competent authority with Registration no..... are eligible to participate in this tender.

[Format for seeking registration for bidders having beneficial ownership in countries which share land border with India and further details refer Notification no P-45021/112/2020-PP (BE-II) (E-43780) dated 14.10.2020 Department of promotion of industry and internal trade , Ministry of Commerce and Industry , Govt. of India .]

(Signature of authorized signatory of the tenderer)

Name:

Designation:

Place

Seal :

Date:



NON – DISCLOSURE AGREEMENT

BETWEEN

BEML LIMITED
BENGALURU

AND

.....

NON – DISCLOSURE AGREEMENT

This Non – Disclosure Agreement (hereinafter referred to as "**NDA**") is made and entered into between ;

M/s BEML LIMITED, a Central Public Sector Undertaking, coming under the administrative control of Ministry of Defence, and a Company incorporated under the Companies Act, 1956, having its Corporate Office at 'BEML SOUDHA',23/1, 4th Main, SR Nagar, Bengaluru – 560027, India (hereinafter referred to as "**BEML**" which expression, unless repugnant to the context, shall mean and include its successors and permitted assigns) of the One Part ,

And

M/s..... (Hereinafter referred to as "**Consultant**" which expression, unless repugnant to the context, shall mean and include its successors and permitted assigns) Other Part.

Hereinafter, BEML and the Consultant are collectively referred to as "**Parties**" and individually as "**Party**".

WHEREAS, BEML is a multi-technology heavy engineering industry engaged in the business of design, development, manufacture and marketing of a variety of equipment and spare parts and aggregates required for Mining &Construction ,Rail and Metro Defence and Aerospace, etc.

Whereas the Firm is engaged in

Whereas BEML intends to procure trackshoe profiles from the firm where the drawings will be shared to the firm. (hereinafter referred to as "**the Purpose**"). If the firm emerged as the successful bidder and agreed to provide his products in accordance with terms and conditions specifically stipulated in -the Tender

Whereas as per the Tender documents the Successful bidder has to execute a Non-Disclosure Agreement on Non-judicial stamp paper before placement of Purchase order

as the Parties may disclose certain Information to each other, and the Parties recognise that careful protection and non-disclosure by the Party receiving the Confidential Information (hereinafter referred to as the "**Receiving Party**") from the Party disclosing such Confidential Information (hereinafter referred to as the "**Disclosing Party**") is of vital importance while executing the purpose.

NOW THEREFORE, in consideration of the mutual promises made herein, the Parties agree to disclose and receive certain Confidential Information only under the following terms and conditions:

1. SCOPE OF THE NDA

1.1. The Parties recognise that there is a need to disclose to one another certain Confidential Information for the purpose. Confidential information is to be used only for the Purpose.

1.2. The following terms and conditions shall apply when the Disclosing Party discloses Confidential Information to the Receiving Party. Nothing contained in this NDA shall be construed as granting rights by the Disclosing Party to the Receiving Party, by license or otherwise, to any of the Confidential Information under any patent, know-how or other rights till now or hereinafter held by the Disclosing Party except as specified in this NDA. The Disclosing Party will provide Confidential Information without warranties of any nature whatsoever.

1.3. The firm should not participate in any tenders published by BEMLS customer in terms of spares or any kind of supply of the products to BEML customers.

2. CONFIDENTIAL INFORMATION

The term "Confidential Information" shall mean and refer to all or any information and data of confidential or proprietary in nature which is disclosed by the Disclosing Party to the Receiving Party, including but not limited to, past, current and future customer information, proprietary, technical, financial, personnel,

marketing, pricing, sales and/or commercial information with respect to the “Purpose” as well as ideas, concepts, designs, drawings and inventions, embedded hardware design, data and information, computer source and object code and computer programming techniques; and all record bearing media containing or disclosing such information and techniques which are disclosed pursuant to this NDA

3. EXCEPTIONS

This NDA imposes no obligation upon the Receiving Party with respect to information that:

- a) is now, or hereafter becomes, through no act or failure to act on the part of the Receiving Party, generally known or available to the public;
- b) is hereafter rightfully furnished to the Receiving Party by a third party, without restrictions to use or disclosure;
- c) is disclosed with the prior written consent of the Disclosing Party; or
- d) is required to be disclosed in pursuant to law, order of the court or Government authority, and then only to the extent ordered by the court or governmental authority, provided that the Receiving Party shall give a notice as early as possible to enable the Disclosing Party to get a protective order.

4. NON-DISCLOSURE

All Confidential Information is and shall remain the property of the Disclosing Party. The Receiving Party agrees to hold the Confidential Information disclosed to it by the disclosing party in strict confidence and will not disclose the Confidential Information to any third party without the prior written consent of the Disclosing party.

5. RECEIVING PARTY'S OBLIGATIONS:

The Receiving Party undertakes:

- a) to use the same care and discretion to avoid disclosure, publication or dissemination of the Confidential Information as it uses with respect to its own Confidential Information, but no less than reasonable care;

- b) not to use the Confidential Information for any other purpose except for the purpose for which the information has been disclosed.
- c) to comply with any other reasonable security measures requested in writing by the Disclosing Party;
- d) not to, under any circumstances, copy, replicate, or reverse engineer any products or services of the Disclosing Party by unauthorised use of Confidential Information and shall not infringe the intellectual property rights law applicable to the Disclosing Party;
- e) not to, directly or indirectly, make or permit any oral or written communications to the public media regarding the Confidential Information of the Disclosing Party, its business or clients or use the name of the Disclosing Party in any public announcements, promotional, marketing or sales materials or efforts, without the express prior approval of the Disclosing Party.
- f) Not to disclose Confidential Information to any third party without the prior consent of the Disclosing party.

- g) to disclose the confidential information to its employees, on a 'need to know' basis for the purpose of this NDA.

6. REMEDIES

The Parties recognise and acknowledge that Confidential Information is of a special, unique and extraordinary character to the Disclosing Party and that disclosure, misappropriation or unauthorized use of such Confidential Information by the Receiving Party cannot be fully compensated and that, further any such disclosure, misappropriation or unauthorized use of the Confidential Information shall cause irreparable injury to the Disclosing Party. The Receiving Party expressly agrees, therefore, that the Disclosing Party, in addition to any rights and remedies it may have under this NDA or at law or in equity, shall be entitled to seek injunctive and other equitable relief to prevent the breach, or the further breach, or any of the terms and provisions hereof. The Receiving Party agrees to reimburse the Disclosing Party for any and all losses, liabilities, damages, costs and expenses (including reasonable attorney's fees and court costs) incurred and sustained by the Disclosing Party as a result of any breach of this NDA

7. TERM

The term of this NDA shall be till the completion of purchase order and that the obligations of the Receiving Party to protect the Confidential Information under this NDA shall survive for a period of two (2) years from the date of its early termination or expiry.

8. TERMINATION

This NDA shall, unless otherwise extended by mutual agreement of the Parties, terminate upon happening of any of the following events :

- (a) Termination by mutual consent.

- (b) Termination by either party due to breach of any of the covenants hereof by the other

- (c) by giving written notice in the event of the liquidation, bankruptcy, reorganization, dissolution or insolvency of the other Party resulting in that Party's inability to perform the obligations under this Agreement;

Notwithstanding the above, termination shall not prejudice any obligation that has arisen prior to the date of effective termination between the Parties and/or obligation of either Party to any other third party.

9. RETURN OF CONFIDENTIAL INFORMATION

Upon the expiry or termination of this NDA or at the earlier request of the Disclosing Party, the Receiving Party shall return all Confidential Information to the Disclosing Party without retaining any copies of such Confidential Information or, if so desired by the Disclosing Party, confirm in writing that all such Confidential Information has been destroyed. Notwithstanding the return or destruction of the Confidential Information, the Receiving Party will continue to be bound by its obligations of confidentiality and other obligations hereunder.

10. DISPUTE SETTLEMENT & JURISDICTION :

Disputes if any, arising between the Parties, in connection with this NDA or any other matters connected therewith, the same will be mutually discussed and amicably settled between the parties, failing which, the disputes shall be referred to Arbitration in accordance with the provisions of Arbitration and Conciliation Act, 1996 and Rules framed there under from time-to-time. The place of Arbitration shall be at Bengaluru and the Arbitration proceedings shall be conducted in English language.

Courts at Bengaluru alone will have jurisdiction to entertain, try and adjudicate any matter connected with this Agreement, including Arbitration.

11. NON-SOLICITATION

No Party shall, either directly or indirectly, on its own behalf or on the behalf of others, solicit or hire for work any person(s) employed by the other Party, whether or not such employment is pursuant to a written contract or is at will, without the express written permission of such other Party, or until such employee has ceased his/her employment with such other Party for at least two (2) years. This clause shall survive for a period of two years even from the date of termination.

12. AMENDMENT

Any amendment or modification of this NDA shall be valid only if the same is in writing and signed by or on behalf of each of the Parties.

13. MISCELLANEOUS

13.1 Severability and Waiver. If any provision of this NDA is held to be invalid or unenforceable for any reason, the remaining provisions shall continue in full

force without being impaired or invalidated in any way. The Parties shall replace any invalid provision with a valid provision, which must closely approximate the intent and economic effect of the invalid provision. The waiver by the Disclosing Party of a breach of any provision of this NDA shall not operate or be interpreted as a waiver of any other or subsequent breach.

13.2.Notices. All notices under this NDA must be in writing and must be either: faxed; mailed by registered or certified mail, postage prepaid and return receipt requested; or delivered by hand to the party to whom such notice is required or permitted to be given at the address set out in the title of this NDA.

IN WITNESS WHEREOF, the Parties hereto have set their respective hands to this NDA on(Day) (Month) (Year)at (Place) in the presence of the following witnesses.

For BEML LIMITED

Firm

Name:

Name:

Signature:

Signature:

WITNESSES :

WITNESSES :

1.

1.

2.

2.

Annexure – F : Agreement Proforma**NONCOMPETITION AGREEMENT**

THIS NON COMPETITION AGREEMENT is made and executed on this the.....day ofat Bangalore **BETWEEN** M/s. BEML Ltd, a Government of India undertaking, having its Registered office at No.23/1, "BEML SOUDHA", 4th Main Road, Sampangirama Nagar, Bangalore – 560 027 (hereinafter called "BEML") and manufacturing units at Kolar Gold Fields, Mysore and Bangalore, which expression shall unless repugnant to the subject or context thereof mean and include its representatives, administrators, successors and assigns etc of the **FIRST PART.**

AND

M/s.....Company, with its Registered Office at.....and manufacturing unit at.....represented by their Shria lawful Attorney, residing at.....(hereinafter called "VENDOR") which expression shall unless repugnant to the subject or context thereof mean and include its representatives, administrators, successors and assigns etc of the SECOND PART.

NOW THIS AGREEMENT WITNESSETH AND IT IS AGREED BY AND BETWEEN THE PARTIES HERETO AS UNDER:

Whereas, BEML will place Purchase Order No.....Dated on the VENDOR for supply ofwhich products are exclusively manufactured to the designs and specifications of BEML.

In pursuance of the placement of the above Purchase Order on M/s.....or M/s or any other Authorized Dealer / Distributor of or any person authorized bythe VENDOR hereby agree and undertake not to quote or supply.....

..... to any other parties in India and as such the VENDOR is prohibited to quote or supply the products specified in the instant Agreement. In contravention of this term, The VENDOR or any other Authorized Dealer / Distributor / Agent of or any person authorized by the VENDOR were to quote and supply

.....to any other parties in India and / or abroad, BEML

would, after giving a reasonable opportunity to explain such quote and supply be entitled to levy

a penalty to the extent of loss occasioned to BEML.

This Non-Competition Agreement will be valid for a period of five years from the date of placement of Purchase Order by BEML on the VENDOR and for all Government / Quasi-Government companies in India and all non-Government Companies in India and abroad. Disputes if any, arising between the parties in connection with this Non-Competition Agreement or any other matters connected therewith, the same will be mutually discussed and settled, failing which, the disputes shall be referred to a Sole Arbitrator to be appointed by BEML. The Arbitration proceedings shall be in accordance with the provisions of Arbitration and Conciliation Act, 1996 and Rules framed there under. The place of Arbitration shall be at Bangalore and all Arbitration proceedings shall be conducted in English language and governed by the above said Act and Rules framed there under. Courts at Bangalore shall alone have sole jurisdiction to decide any issue arising out of the Arbitration or this Non-Competition Agreement.

Thanking you

Yours faithfully,

For BEML LIMITED

Annexure (J)

(To be executed on plain paper and applicable for all tenders of value _ Rs. 1 Crore and above)

INTEGRITY PACT

Between

BEML Limited (BEML) hereinafter referred to as “The Principal”

And

..... hereinafter referred to as “The Bidder/Contractor”

Preamble

The Principal intends to award, under laid down organizational procedures, contract/s for

.....

The Principal values full compliance with all relevant laws of the land, rules, regulations, economic use of resources and of fairness / transparency in its relations with its Bidder(s) and / or Contractor(s).

In order to achieve these goals, the Principal will appoint an independent External Monitor (IEM), who will monitor the tender process and the execution of the contract for compliance with the principles mentioned above.

Section 1 – Commitments of the Principal

(1) The Principal commits itself to take all measures necessary to prevent corruption and to observe the following principles:

- a) No employee of the Principal, personally or through family members, will in connection with the tender for, or the execution of a contract, demand, take a promise for or accept, for self or third person, any material or immaterial benefit which the person is not legally entitled to.
- b) The Principal will, during the tender process treat all Bidder(s) with equity and reason. The Principal will in particular, before and during the tender process, provide to all Bidder(s) the same information and will not provide to any Bidder(s) confidential/ additional information through which the Bidder(s) could obtain an advantage in relation to the tender process or the contract execution.
- c) The Principal will exclude from the process all known prejudiced persons.

(2) If the principal obtains information on the conduct of any of its employees which is a criminal offence under the IPC/PC Act, or it there be a substantive suspicion in this regard, the Principal will inform the Chief Vigilance Officer and in addition can initiate disciplinary actions.

Section 2 – Commitment of the Bidder(s)/ contractor(s)

- (1) The Bidder(s)/ Contractor(s) commit themselves to take all measures necessary to prevent corruption. He commits himself to observe the following principles during his participation in the tender process and during the contract execution.
 - a) The Bidder(s)/ Contractor(s) will not, directly or through any other person or firm, offer, promise or give to any of the Principal’s employees involved in the tender process or the execution of the contract or to any third person any material or other benefit which he/she is not legally entitled to, in order to obtain in exchange any advantage of any kind whatsoever during the tender process or during the execution of the contract.
 - b) The Bidder(s)/ Contractor(s) will not enter with other Bidders into any undisclosed agreement or understanding, whether formal or informal. This applies in particular to prices, specifications, certifications, subsidiary contracts, submission or non-submission of bids or any other actions to restrict competitiveness or to introduce cartelization in the bidding process.
 - c) The Bidder(s)/ Contractor(s) will not commit any offence under the relevant IPC/PC Act; further, the Bidder(s) / Contractor(s) will not use improperly, for purposes of competition or personal gain, or pass on to others, any information or documents provided by the Principal as part of the business relationship, regarding plans, technical proposals and business details, including information contained or transmitted electronically.
 - d) The Bidder(s)/ Contractor(s) of foreign origin shall disclose the name and address of the Agents/ Representatives in India, if any. Similarly, the Bidder(s)/ Contractor(s) of Indian Nationality shall furnish the name and address of the foreign Principals, if any. Further, as mentioned in the “Guidelines on Indian Agents of Foreign Suppliers” shall be disclosed by the Bidder(s)/Contractor(s). Further, as mentioned in the Guidelines all the payments made to the Indian agent/representative have to be in Indian Rupees only. Copy of the “Guidelines on Indian Agents of Foreign Suppliers” is placed at **Annexure (J-1)**.
 - e) The Bidder(s) / Contractor(s) will, when presenting his bid, disclose any and all payments he has made, is committed to or intends to make to agents, brokers or any other intermediaries in connection with the award of the contract.
- (2) The Bidder(s)/Contractor(s) will not instigate third persons to commit offences outlined above or be an accessory to such offences.

Section 3 – Disqualification from tender process and exclusion from future contracts

If the Bidder(s)/Contractor(s), before award or during execution has committed a transgression through a violation of Section 2, above or any other form such as to put his reliability or creditability in question, the Principal is entitled to disqualify the Bidder(s)/Contractor(s) from the tender process or act as per the procedure mentioned in the “Guidelines on Banning of business dealings”.

Section 4 – Compensation for Damages

- (1) If the Principal has disqualified the Bidder(s) from the tender process prior to the award according to Section 3, the Principal is entitled to demand and recover the damages equivalent to Earnest Money Deposit/ Bid Security.
- (2) If the Principal has terminated the contract according to Section 3, or if the Principal is entitled to terminate the contract according to Section 3, the Principal shall be entitled to demand and recover from the Contractor liquidated damages of the contract value or the amount equivalent to Performance Bank Guarantee.

Section 5 – Previous Transgression

- (1) The Bidders declares that no previous transgressions occurred in the last three years with any other Company in any country conforming to the anti-corruption approach or with any other Public Sector Enterprises in India that could justify his exclusion from the tender process.
- (2) If the Bidder makes incorrect statement on this subject, he can be disqualified from the tender process or action can be taken as per the procedure mentioned in “Guidelines on Banning of business dealings”.

Section 6 – Equal treatment of all Bidders /Contractors /Sub-contractors

- (1) The Bidder(s)/ Contractor(s) undertaker(s) to demand from all subcontractors a commitment in conformity with this Integrity Pact, and to submit it to the Principal before contract signing.
- (2) The Principal will enter into agreement with identical conditions as this one with all Bidders, Contractors and subcontractors.
- (3) The Principal will disqualify from the tender process all bidders who do not sign this Pact or violate its provisions.

Section 7 – Criminal charges against violating Bidder(s) / Contractor(s) / Subcontractor(s)

If the Principal obtains knowledge of conduct of a Bidder, Contractor or Subcontractor, or of an employee or a representative or an associate of a Bidder, Contractor or Subcontractor which constitutes corruption, or of the Principal has substantive suspicion in this regard, the Principal will inform the same to the Chief Vigilance Officer

Section 8 – Independent External Monitor / Monitors

- (1) The Principal appoints competent and credible Independent External Monitor for this Pact. The task of the Monitor is to review independently and objectively, whether and to what extent the parties comply with the obligations under this agreement
- (2) The Monitor is not subject to instructions by the representatives of the parties and performs his functions neutrally and independently. It will be obligatory for him to treat the information and documents of the Bidders/Contractors as confidential. He reports to the CMD, BEML.
- (3) The Bidder(s)/ Contractor(s) accepts that the Monitor has the right to access without restriction to all Project documentation of the Principal including that provided by the Contractor. The Contractor will also grant the Monitor, upon his request and demonstration of a valid interest, unrestricted and unconditional access to his project documentation. The same is applicable to Subcontractors. The Monitor is under contractual obligation to treat the information and documents of the Bidder(s)/ Contractor(s) / Subcontractor(s) with confidentiality.
- (4) The Principal will provide to the Monitor sufficient information about all meetings among the parties related to the Project provided such meetings could have an impact on the contractual relations between the Principal and the Contractor. The parties offer to the Monitor the option to participate in such meetings.
- (5) As soon as the Monitor notices, or believes to notice, a violation of this agreement, he will so inform the Management of the Principal and request the Management to discontinue or take corrective action, or to take other relevant action. The monitor can in this regard submit non-binding recommendations. Beyond this, the Monitor has no right to demand from the parties that they act in a specific manner, refrain from action or tolerate action.
- (6) The Monitor will submit a written report to the CMD, BEML, within 8 to 10 weeks from the date of reference or intimation to him by the Principal and, should the occasion arise submit proposals for correcting problematic situations.
- (7) If the Monitor has reported to the CMD, BEML, a substantiated suspicion of an offence under relevant IPC/PC Act, and the CMD, BEML has not, within the reasonable time taken visible

action to proceed against such offence or reported it to the Chief Vigilance Officer, the Monitor may also transmit this information directly to the Central Vigilance Commissioner.

- (8) The word 'Monitor' would include both singular and plural.

Section 9 – Pact Duration

This pact begins when both parties have legally signed it. It expires for the Contractor 12 months after the last payment under the contract, and for all other Bidders 6 months after the contract has been awarded. If any claim is made/lodged during this time, the same shall be binding and continue to be valid despite the lapse of this pact as specified above, unless it is discharged/ determined by CMD of BEML

Section 10 – Other provisions

- (1) This agreement is subject to Indian Law. Place of performance and jurisdiction is the Corporate Office of the Principal, i.e. Bangalore.
- (2) Changes and supplements as well as termination notices need to be made in writing. Side agreements have not been made.
- (3) If the Contractor is a partnership or a consortium, this agreement must be signed by all partners or consortium members.
- (4) Should one or several provisions of this agreement turn out to be invalid, the reminder of this agreement remains valid. In this case, the parties will strive to come to an agreement to their original intentions.
- (5) The bidder shall not approach the Courts while representing the matters to IEMs and he/ she will await their decision in the matter.
- (6) In case of joint venture, all the partners of the joint venture should sign the Integrity Pact. In case of sub-contracting, the Principal contractor shall take the responsibility of the adoption of IP by the sub-contractor. It is to be ensured that all sub- contractors also sign IP.

(7) In the event of any dispute between the management and the contractor relating to those contracts where Integrity Pact is applicable, in case, both the parties are agreeable, they may try to settle dispute through mediation before the panel of IEMs in a time bound manner. If required, the organization may adopt any mediation rules for this purpose.

In case, the dispute remains unresolved even after mediation by the panel of IEMs, the organization may take further action as per the terms and conditions of the contract.

The fees / expenses on dispute resolution shall be equally shared by both the parties.

(8) In the event of any contradiction between the Integrity Pact and its Annexure, the Clause in the integrity pact will prevail

(For & On behalf of the Principal)

(For & On behalf of Bidder/Contractor)

(Office Seal)

(Office Seal)

Place-----

Place-----

Date -----

Date -----

Witness 1:
(Name & Address)

Witness 1:
(Name & Address)

Witness 2:
(Name & Address)

Witness 2:
(Name & Address)

Annexure J-1
GUIDELINES FOR INDIAN AGENTS OF FOREIGN SUPPLIERS

- 1.0 There shall be compulsory registration of agents for all Global (Open) Tender and Limited Tender. An agent who is not registered with BEML LTD shall apply for registration in the prescribed Application-Form available on *www.bemlindia.in*.
- 1.1 Registered agents will file an authenticated Photostat copy duly attested by a Notary Public/Original certificate of the principal confirming the agency agreement and giving the status being enjoyed by the agent and the commission/remuneration/ salary/ retainer ship being paid by the principal to the agent before the placement of order by BEML LTD.
- 1.2 Wherever the Indian representatives have communicated on behalf of their principals and the foreign parties have stated that they are not paying any commission to the Indian agents, and the Indian representative is working on the basis of salary or as retainer, a written declaration to this effect should be submitted by the party (i.e. Principal) before finalizing the order.

- 2.0 DISCLOSURE OF PARTICULARS OF AGENTS/ REPRESENTATIVES IN INDIA, IF ANY:
 - 2.1 Tenderers of Foreign nationality shall furnish the following details in their offer:
 - 2.1.1 The name and address of the agents/representatives in India, if any and the extent of authorization and authority given to commit the Principals. In case the agent/representative be a foreign Company, it shall be confirmed whether it is real substantial Company and details of the same shall be furnished.
 - 2.1.2 The amount of commission/remuneration included in the quoted price(s) for such agents/representatives in India.
 - 2.1.3 Confirmation of the Tenderer that the commission/ remuneration if any, payable to his agents/representatives in India, may be paid by BEML LTD in Indian Rupees only.
 - 2.2 Tenderers of Indian Nationality shall furnish the following details in their offers:
 - 2.2.1 The name and address of the foreign principals indicating their nationality as well as their status, i.e, whether manufacturer or agents of manufacturer holding the Letter of Authority of the Principal specifically authorizing the agent to make an offer in India in response to tender either directly or through the agents/representatives.
 - 2.2.2 The amount of commission/remuneration included in the price (s) quoted by the Tenderer for himself.
 - 2.2.3 Confirmation of the foreign principals of the Tenderer that the commission/remuneration, if any, reserved for the Tenderer in the quoted price (s), may be paid by BEML LTD in India in equivalent Indian Rupees on satisfactory completion of the Project or supplies of Stores and Spares in case of operation items.
 - 2.3 In either case, in the event of contract materializing, the terms of payment will provide for payment of the commission /remuneration, if any payable to the agents/representatives in India in Indian Rupees on expiry of 90 days after the discharge of the obligations under the contract.
 - 2.4 Failure to furnish correct and detailed information as called for in paragraph-2.0 above will render the concerned tender liable to rejection or in the event of a contract materializing, the same liable to termination by BEML LTD. Besides this there would be a penalty of banning business dealings with BEML LTD or damage or payment of a named sum.

Signature
(For & On behalf of Bidder/Contractor)

GENERAL TERMS & CONDITIONS FOR PROCUREMENT OF MATERIALS SINGLE BID

1. DEFINITIONS& INTERPRETATIONS:

- 1.1 The Purchaser' means "(include company name and address)" (A Government of India Undertaking) incorporated under the Companies Act having its registered office at "BEML Soudha, No 23/1, 4th main, S.R. Nagar, Bengaluru – 560027" and shall be deemed to include its successors and assignee.
- 1.2 Supplier' means a person having been included in a contract as a Contractor and also means a firm or company with whom the order for supply/execution of work is placed and shall be deemed to include the supplier's successors, (approved by BEML Ltd.,) representatives, heirs, executors and administrators. The supplier may also be referred to as the supplier, Contractor or vendor.
- 1.3 Parties to the Contract' shall mean the Supplier and the Purchaser as named in the main body of the Purchase Order.
- 1.4 Tender' means and includes quotation, invitation to tender and all other documents like drawings, specifications, quality plan, etc that form part of the tender document.
- 1.5 Acceptance of Tender' Means the letter of memorandum communicating supplier, the acceptance of the Tender and includes advance acceptance of this tender.
- 1.6 Purchase Orders / Contract' means and includes the invitation to tender, instruction to Tenderers, acceptance of tender, Letter of intent / letter of award, the general terms and conditions of Purchase Order / contract, special conditions of Purchase Order /contract, particulars, descriptions, specifications, schedule of prices, quantities, quality plan, drawings enclosed and other condition specified in the acceptance of tenders and includes the repeat order which has been accepted or acted upon by / for the supplier for the supply of stores and includes an order for performance of service and includes amendments, if any, that may take place subsequent to the discussions, negotiations, mutual agreement if any.
- 1.7 Stores / Materials / Services' means the goods or services specified in the Purchase Order which the supplier has agreed to supply under the Purchase Order.
- 1.8 Words in singular include the plural & vice-versa.
- 1.9 Words imparting the masculine gender shall be taken to include the feminine gender and words imparting persons shall include any firm, company or associations or body of individuals whether incorporated or not.
- 1.10 The heading of these conditions shall not affect the interpretations or construction thereof of the contract.

2.0 GENERAL TERMS & CONDITIONS FOR PROCUREMENT OF MATERIALS (e-mode)

- a) The tenderer is advised to carefully go through the tender terms & conditions before submitting the tender
- b) INSTRUCTIONS FOR SUBMISSION OF THE TENDER: Tender is in SINGLE BID system
- c) Bids should be submitted online in BEML SRM e-Procurement platform only. Bidders should have a valid Class III Digital Signature Certificate with encryption issued by Authorized Certifying Authority to submit your bid in BEML SRM e-Procurement system. Interested bidders can contact us through e-mail: admin.srm@beml.co.in to obtain the username and password for submitting the bids.

2.1 INSTRUCTION FOR SUBMISSION BID:

- a) The firm should submit their Bids through E-mode in BEML SRM Portal only. Please quote the price details in the 'Price Conditions' column in SRM portal against the respective item.
 - b) The Bidder should upload all the documents along with respective supporting documents which is specified in the tender. If the bidder has not provided the document which is specified their offer is liable for rejection.
 - c) Only GST registered vendor needs to quote. Firm has to update registered GST details in BEML SRM website to submit quotation (non local vendors).
- 2.2 Quote should also indicate the Minimum lead time & Ex-stock availability.
- 2.3 Break-up cost for the quoted price to be provided in the quotation such as Material cost, Labour cost, other overhead cost.
- 2.4 Supplies should be strictly as per the requirement projected. The item supplied should be GENUINE PART as it is used for OE requirement.
- 2.5 Along with supplies, as mentioned in Bid, it is required to submit Inspection certificate, material test reports (from NABL accredited Lab for BEML Defence parts), warranty certificate, Country of Origin certificate & other related documents required along with the shipment.
- 2.6 If dealers are submitting the bids in place of OEM, Dealer should submit Authority letter from manufacturer.
- 2.7 If sister concern exists then only one bidder to participate.
- 2.8 BEML reserves its right to reject a tender due to unsatisfactory past performance in the execution of a contract at any of BEML projects / units.

- 2.9 BEML reserves its right to reject any incomplete bid submitted.
- 2.10 The due date for submission of tenders may be extended by BEML, **in its sole discretion**, which shall be announced as **corrigendum to original NIT only at our website/ SRM Portal**. Validity of bids submitted shall be deemed to be extended accordingly.
- 2.11 BEML may decide to scrap the tender/refloat the tender without assigning any reasons thereof before LOI/PO is committed. BEML reserves the right to accept, split, divide, negotiate, cancel or reject any tender or reject all tenders at any time prior to the award of the contract without incurring any liability to the affected tenderers or any obligation to inform affected tenderer, the grounds of such action.
- 2.12 The correspondence exchanged against the tender from both tenderer and BEML through official email are considered as valid document legally though it is not signed. It is treated as valid confirmations made on behalf of the respective company and very much comes under the legal ambit of the business transaction and hence it is binding on both the parties to the business.
- 2.13 Bidders participating in the tender should declare in their offer that whether they have been black- listed / kept on hold for a specified period / given Business holiday for a specified period by any Public sector undertaking or Government departments. The reasons for such action with details and the current status of such hold shall be furnished to BEML.
- 2.14 If no such details are mentioned in the offer then it will be construed that the subject bidder is not under any such hold. But at a later date if it comes to the notice of BEML about any such hold under enforcement on the subject bidder, BEML will have every right to reject the offer of such vendors at any point of time and also under any stage of the finalization of the subject tender irrespective of the status of the subject bidder in that tender.
- 2.15 BEML reserves the right to verify, in its sole discretion, any information given by the bidders independently through any third party agencies. During this process, if it is found that any of the information given by the bidder is false / misleading, offers of such bidders would be out rightly rejected.
- 2.16 BEML also reserves the right to independently assess the capability and capacity of the bidder for execution of the order/contract. BEML's decision on any matter regarding short listing of bidders shall be final.
- 2.17 The RFx / Notice Inviting Tender is not an offer or a contract.
- 2.18 Proposals become BEML's property.
- 2.19 Bidders will not be compensated or reimbursed for the costs incurred in preparing Proposals.

- 2.20 BEML is not obligated to contract for any of the products described in the RFx/ Notice Inviting Tender.
- 2.21 BEML's decision is final for Evaluation of the offers.
- 2.22 Quotation submitted through Manual mode or E-mail or fax will not be considered and it is liable for rejection.
- 2.23 Unsolicited letters/canvassing/post tender corrections canvassing by Tenderers in any form including unsolicited letters on tenders submitted or post tender corrections shall render their tenders liable for summary rejection.
- 2.24 In case any person/persons, Company, firm, Associations having any litigations, arbitration cases between themselves and BEML Ltd, pending before the Court / Arbitrator or initiated litigations/arbitrations in connection with any contract / tender issued by BEML Ltd and any contractor has defaulted against the BEML's orders are not eligible to participate in this tender.
- 2.25 The uploaded documents in the SRM Portal should be legible & readable. If required, the entire Original documents (of Uploaded Documents in SRM Portal) have to be submitted if asked for from BEML Ltd. If Original documents are not submitted when asked for, their Bid will be liable for rejection.
- 2.26 Bidders/contractors are requested to put the page numbers and signed in all the documents which are uploaded in the SRM portal.
- 2.27 Late / Un-Solicited offers will be rejected.
- 2.28 In case if purchase order is already issued by BEML, BEML reserves the right to cancel the order without assigning any reasons thereof. Such bidders will not be permitted to participate in the further tender proceedings and will be communicated suitably. They will not be also considered for any ongoing tenders even if participated till the hold is officially lifted and confirmed in writing.
- 2.29 Overseas bidders may authorize their Indian representative to represent them, to bid, negotiate (technically and commercially) and conclude the contract on their behalf. They must submit valid authorization letter specific to this tender, in this regard along with the bid. However, the purchase order shall be directly placed in the name of overseas bidder only and they shall be fully responsible for successful execution of contract including after-sales service in all respect.
- 2.30 Maximum possible quantity supply per month to be indicated in the quotation in case of capacity constraint.
- 2.31 If you are not able to quote, please send your Regret Letter with reasons for regretting
- 2.32 We request you to submit your lowest non-negotiable best competitive price.

2.33 The quoted prices should be firm and fixed for the entire shipments, unless otherwise agreed specifically in the contract with breakup of statutory levies if applicable.

2.34 Installation and commissioning to be done by supplier at BEML site and bidder to indicate the period required for the above job from the date of intimation of readiness of site at our premises.

2.35 The vendor may visit our works with prior intimation & confirmation from our end to study existing facility BEML.

2.36 No representation would be entertained on any error(s) if found in the NIT. However, vendor(s) shall bring such errors / omissions to notice of BEML for necessary corrective action(s). The vendor's time and expenses has to be borne by vendor(s).

3.0 Public Procurement – Preference to Make in India Policy: The procurement and placement of order is subject to **Public Procurement (Preference to Make in India) Order 2017** issue by the Ministry of Commerce and Industry, Department of Industrial Policy & Promotion, Government of India vide No.**P-45021/2/2017-B-E-II dt 15thJune 2017**. The full details of the order can be seen at <http://dipp.nic.in/whats-new/public-procurement-preference-make-india-order-2017>.

4.0 PRICE BID VALIDITY: The Bid should be valid for 90 days from the date of tender opening. BEML's acceptance of the tender at the quoted / negotiated rates will be binding on the tenderer during the tenure of contract

5.0 DELIVERY TERMS: Except as otherwise indicated in the Purchase Order, delivery shall be FOR (BEML). Trade terms such as EXW, FOB, CFR etc., if stipulated in the order shall be construed in accordance with the version of the INCOTERMS applicable at the time of ordering, without prejudice to the provisions contained in these conditions. The delivery date(s) or delivery period(s) as stipulated in the agreement shall be firm and binding and shall apply to the entire delivery for each PO item. Partial shipments may, however, be permitted by the purchaser. The time and the date of delivery of the stores stipulated in the PO No. shall be deemed to be the essence of the Purchase Order and delivery must be completed not later than the dates specified therein. The supplier shall strictly adhere to the delivery schedule indicated in the P.O. Any supplies made ahead of this schedule are liable for rejection at the discretion of BEML. Shall the supplier fail to deliver the stores or any consignment thereof within the period prescribed for such delivery BEML shall be entitled at their option either.

a. To purchase elsewhere, without notice to the supplier on the account and at the risk and cost of the supplier the stores not delivered or other of a similar description where stores exactly comply with the description are not in the opinion of BEML (which shall be final, readily procurable) without cancelling the P.O. in respect of consignments not yet due for delivery.

Or

b. To cancel the Purchase Order

In the event of action being taken under (a) or (b) the supplier shall be liable for any loss which BEML may sustain on that account but the supplier shall not be entitled to any gain on purchase made against default. As soon as it is apparent that the scheduled dates cannot be

adhered to, an application shall be sent by the supplier to BEML, well before the expiry of the delivery period specified in the Purchase Order. Without prejudice to the foregoing rights, if such failure to deliver in proper time as aforesaid shall have arisen from any cause which BEML may admit as a reasonable ground for an extension of the time (and their decision shall be final) they may allow such additional time as they may consider justified by circumstances of the case. Delivery required to be made in lots shall be made in lots only and any extra deliveries involved either on account of repeated rejections or variance in supply or loss shall be liable for service charges of 5% of the Purchase Order value for each extra delivery.

6.0 PAYMENT TERM:

Term of payment is 100% payment on 30th day for MSEs and for others on 60th day from the date of receipt of material at BEML stores subject to inspection and acceptance of materials. For Bidders not agreeing with the above terms, their quotations will be suitably loaded with applicable cash credit interest while evaluation of bids. In case of early supplies, payment will be made only as per the delivery schedule indicated in the purchase order and in line with the terms of payment. No Advance payment would be done.

7.0 PENALTY / LIQUIDATED DAMAGES:

The time or period of delivery as stipulated in the schedule of delivery shall be deemed to be essence of the Contract. Shall circumstances arise whereby the deadline for an agreed delivery date(s) or period(s) is expected to be exceeded, the Supplier shall inform Purchaser without delay that in such an event the Supplier shall bind himself to any of the terms and conditions that may be imposed by the Purchaser. If delay in delivery is caused by any of the circumstances mentioned is on account of Force Majeure conditions prior to the scheduled / extended delivery or by additional work, if any, or by an act or omission on the part of the Purchaser, the Purchaser shall extend the time for delivery by a period which is reasonable having regard to all the circumstances in the case. If the Supplier exceeds any agreed delivery date(s) or period(s), Purchaser shall levy LD for such delay @0.5% per week (7 days) and part thereof, subject to a maximum of 5% of the value of the delayed portion of the Purchase Order. The penalty / LD will be charged on the value of the Purchase Order excluding statutory levies freight and insurance wherever not included in the price. Imposition, recovery or settlement of this LD shall not affect Purchaser's right to performance, compensation and termination of the agreement.

8.0 AUTHORITY OF PERSONS SIGNING DOCUMENT: A person signing the tender or any other document in respect of the Purchase Order shall be deemed to have power to do so on behalf of the Supplier.

9.0 Evaluation of tenders:

a Bids are opened on the stipulated due date and time mentioned in the tender.

b. In the tender document / quotation the figures written in words will be ultimately considered for commercial evaluation ignoring numerical figures in case of discrepancy noticed between the numerical figures of price & price written in words.

10.0 FIRM PRICE: The prices remain firm during the pendency of the contract and no escalation shall be entertained under any circumstances for long term contract

11.0 ACCEPTANCE OF ORDER: The supplier shall send Order Acceptance within two weeks from the date of LOI / LOA / Purchase Order or such other period as specified / agreed by the Purchaser. Purchaser reserves the right to revoke the order placed if the order confirmation

differs from the original Purchase Order placed and the Purchaser shall only be legally bound after it has agreed explicitly in writing to be in agreement with the deviation. The acceptance of deliveries or supplies by Purchaser as well as payments made in this regard shall not imply acceptance of any deviations. The Purchase Order will be deemed to have been accepted if no communication to the contrary is received within two weeks (or the time limit as specified / agreed by the Purchaser) of the receipt of the order.

12.0 SECURITY DEPOSIT / PERFORMANCE GUARANTEE (if applicable)

10 % of PO value has to be deposited as interest free security deposit/Performance Guarantee at the time of acceptance of offer in respect of all service contracts and major capital goods like plant and machinery, etc as follows:

(i) Bank guarantee for faithful performance (FPBG), Combined Bank Guarantee for contract performance covering delivery obligation and warranty (CBG) clause for 10% of the total order value shall be applicable where the order value exceeds Rs.5.00 lakhs. Bank guarantee for faithful performance, combined bank guarantee covering both contract performance and warranty, Advance Payment guarantee etc., shall be indicated wherever applicable.

(ii) A period of 60 days time from the date of Purchase Order or the delivery schedule, whichever is earlier shall be stipulated for submission of Bank Guarantee so that contractual remedies could be enforced, if required.

(iii) A bank guarantee for a nominal amount of Rs.5000/- must be obtained from each Sub-contractor valid for a year, on yearly basis

BEML reserves the right to accept a bank guarantee from any of the Scheduled Commercial Banks authorised by RBI in lieu of cash deposit as security deposit as calculated above at its sole discretion. These bank guarantees shall be valid for the full supply period of the Purchase Order with a claim period of three months.

No claim shall lie against BEML Ltd., in respect of interest on cash deposits or Govt. Securities depreciation thereof.

BEML Ltd. shall be entitled and it shall be lawful on its part to forfeit the said security deposit in whole or in part in the event of any default, failure or neglect on the part of the supplier in the fulfilment or performance in all respect of the Purchase Order.

13.0 PRICE, INVOICING AND PAYMENT: The agreed prices are fixed prices in the currency as specified in the Purchase Order. They shall include packing, forwarding, loading and carriage to the place specified by the Purchaser and are inclusive of all applicable taxes, duties etc. except for those specifically agreed between the supplier and purchaser. The method of invoicing shall be without prejudice to the parties; agreement as to the place of performance. Invoices shall be submitted bearing the Purchase Order number & date, item number / s and supporting documents as called for in the Purchase Order.

14.0 VALIDITY PERIOD : The Purchase Order is valid for a maximum period for 24 months from the date of issue unless otherwise stated, within which time the supplier shall complete the supplies failing which the Purchase Order shall be treated as cancelled / short closed unless it is revalidated against specific request for reasons acceptable to BEML Ltd.,

15.0 PLANT & MACHINERY SUPPLY

In case of Purchase Order for supply of Plant & Machinery and supplies requiring inspection and test after erection and commissioning at site if the completed Plant if any portion thereof or after it is taken over is found to be defective or fails to fulfill the requirements of the P.O. BEML shall give the supplier, notice setting forth details of such defects or failures, and the supplier shall forth with make the defective plant good, or after the same to make it comply with the requirements of the P.O. shall he fail to do so within a reasonable time BEML may reject and replace at the cost of the supplier the whole or any portion of the Plant / Machinery, as the case may be which is defective or fails to fulfil the requirements.

16.0 PROGRESS REPORT:

The supplier shall regularly inform the progress of work and in such form as may be called for by the Purchaser from time to time. The submission and acceptance of such reports shall not prejudice the rights of the Purchaser in any manner.

17.0 CONTRACT VARIATIONS: INCREASE OR DECREASE IN THE SCOPE OF SUPPLY:

Purchaser may vary the contracted scope. If the supplier is of the opinion that the variation in scope has an effect on the agreed price or delivery period, purchaser shall be informed of this immediately in writing along with technical details, and in the event of additional work, submit a quotation with regards to the price and delivery period and the effect this scope will have on the other contracts under execution by the supplier. The supplier shall not perform additional work / altered scope of work without the written instructions / amendment to the Purchase Order to that effect. The Purchaser also reserves its rights to decrease the scope of supply placed against Purchase Orders under due intimation to the supplier. Such decrease may be warranted due to defective goods or Policy Decisions of the Management of the Purchaser. And in such an event, the Supplier shall not have any claims or right against the Purchaser.

18.0. INSPECTION AND TESTING:—The goods and stores shall be of approved design and each part / component may be inspected and tested by the Purchaser prior to shipment and shall fully comply with relevant requirements of purchaser:-

Purchaser has the right to inspect the delivery. In the event of rejection, Purchaser shall inform the Supplier accordingly and Purchaser shall be entitled to replacement or repair at its discretion or may proceed to terminate or annul the agreement. All this does not affect Purchaser's right to compensation.

In case the goods / stores are rejected at the time of inspection at BEML or the rejections are notices at the time of further processing the supplier will be informed of these rejections. On receipt of this information the supplier shall immediately arrange to collect the rejected items at his cost and risk and arrange for the replacement of goods within the shortest possible time. Under no circumstances the supplier shall compel the Purchaser to rework the rejected goods.

Wherever the supplier has not collected the rejected items within 60 days from the date of intimation, BEML shall have the right to dispose the goods and all cost related to the cost of material, statutory levies incurred both in procurement and disposal shall be recovered from

the supplier from any of the bills that are due. The supplier shall have no claims whatsoever against the Purchaser for such disposal.

Purchaser or his authorized representative shall be entitled at all reasonable times during execution to inspect, examine and test at the Supplier's premises the material and workmanship of all stores to be supplied under the Contract, and if the part of the stores are being manufactured at other premises the Supplier shall obtain Purchaser's or his authorized representative's permission to inspect, examine and test as if the said stores are being manufactured at the Supplier's premises. Such inspection, examination and testing, if made shall not release the Supplier from any obligation under the Contract.

All costs related to inspections and re-inspections shall be borne by the Supplier. The cost of inspection staff / third party specified by the Purchaser shall be borne by Purchaser, unless otherwise specifically agreed. Whether the Contract provides for tests on the premises of the Supplier or any of his Sub-contractor/s, Supplier shall be responsible to provide assistance such as, labour, materials, electricity, fuels, stores, apparatus, instruments as may be required and as may be reasonably demanded to carry out such tests efficiently. Cost of any type test or such other special tests shall be borne by the Purchaser only if specifically agreed.

The supplier shall give the authorized representative of the Purchaser reasonable prior notice in writing of the date on and the place at which any stores will be ready for inspection / testing as provided in the Contract.

19.0 QUALITY AND WORKMANSHIP: The stores supplied shall be of the best quality and Workmanship shall be in strict conformity with all the drawings and specifications furnished with the Purchase Orders and shall answer to the description in all respects. All supplies shall be accompanied by supplier's works inspections / test certificates duly certifying, the Stores are in strict conformity with the drawings / specifications. However, final acceptance will be subject to inspection and approval at BEML works. Once the materials are rejected and communicated to the supplier, no request shall be entertained for re-inspection or acceptance of the stores. However, BEML reserves the right to re-inspect the stores and consider acceptance at its discretion.

20.0 SUPPLY OF SAMPLE:(if applicable) The Contractor shall produce samples of all materials and shall obtain approval before he places bulk order for the material for incorporation in the works. In respect of materials for which samples are not kept or detailed specifications is not given hereinafter, such materials shall comply with the latest relevant Indian Standard Specifications as published up to the date of issue of this tender. The Contractor shall on demand produce original receipts vouchers/invoices in respects of materials supplied by him.

21.0 RAW MATERIALS ARRANGEMENT: The Supplier shall make his own arrangement to procure all raw materials required and BEML shall not be responsible for any assistance in such procurement or whatsoever.

22. 0 QUALITY & CONDITION OF DELIVERY: The Supplier shall guarantee that the delivery is of good quality and free from all defects and in the case of services rendered that they are performed by skilled personnel and that new materials are used. The Supplier shall guarantee that the delivery corresponds exactly with the provisions of the agreement, the reasonable expectations of Purchaser regarding the characteristics, quality and reliability of delivery. The

Supplier guarantees that the delivery is suitable for the purpose for which it is intended by its very nature or which is evident from the specifications listed and from the order.

The Supplier shall guarantee that the delivery complies with legal requirements applicable in India and other (international) Government regulations, as applicable. The Supplier guarantees that the delivery complies with legal requirements applicable in India and other (international) Government regulations, as applicable. The supplier shall guarantee that the delivery complies with the customary norms and standards in the relevant branch of trade or industry. The supplier shall be responsible for compliance with applicable technical, safety, quality, environmental requirements and other regulations in relation to his product, packaging, and raw and ancillary materials.

23.0 GUARANTEE / WARRANTY :

a. Guarantee

Wherever required, and so provided in the specifications / Purchaser Order, the Supplier shall guarantee that the stores supplied shall comply with the specifications laid down, for materials, workmanship and performance. If within the guarantee period the delivery is found to be non-compliant including those with the stipulations (in clause Quality and Condition of Delivery) of these Conditions, the Supplier shall, on its own account, replace, repair, or re-execute the delivery at Purchaser's discretion when first requested to do so within two weeks or mutually agreed period, without prejudice to Purchaser's other legal rights. If the Supplier continues to default on its obligations, Purchaser has the right to proceed to replace, repair or re-execute the order at the Supplier's expense, with or without help from third parties besides, Purchaser's other legal remedies. Purchaser shall notify the Supplier of the exercise of this right in advance where possible. Unless otherwise specified, guarantee period shall be 18 months after the date of delivery of goods. For capital goods or bought out packages which are intended to be incorporated in installations or systems the Guarantee period shall not start until the time the installations or systems are commissioned, provided always that the period ends no later than 30 months after the date of delivery of the goods. The guarantee period shall be extended by the period during which the goods are not in compliance with the stipulations in Clause 10 (Quality and Condition of Delivery). A guarantee period as described above shall apply afresh to replaced, repaired or reexecuted parts of a delivery.

The decision of the Purchaser in regard to the Supplier liability under this clause shall be conclusive and final and will be binding on the supplier.

b. Warranty

All the stores supplied shall be warranted against any defect in material, Workmanship, design or dimension etc., for a period of twelve calendar months from the date they are actually put on use or eighteen months from the date of receipt of supply in BEML Limited whichever is earlier and the supplier shall remedy such defects at his/her own cost or replace free of charge such stores when called upon to do so by BEML who shall stage in writing in what respect the stores are defective. Warranty Certificate shall be furnished by the Supplier in triplicate as under covering the entire supplies to be made against this order within 15 days from the date of order, but before commencement of supplies.

The supplies covered under P.O.No. date by Warranted against all defects in material, workmanship, design dimensions etc., for a period of 12 months from the date they are put to actual use or 18 months from the date of receipt of supply in BEML whichever is earlier and if any defects are found within the above period for any of the reasons stated, they will be replaced at your premises free of cost within a reasonable time.

24.0 In case of non adherence to delivery schedule, BEML reserves the right to cancel the order and Risk Purchase clause will be applicable as below :

- a. If a Supplier fails to deliver the goods against an order by the delivery date agreed in the order or if he fails to perform in accordance with the contract conditions, he commits breach of contract. The breach generally gives the Buyers right to cancel the Order, besides claim for damages. The time of delivery can, however, be extended with the consent of both the parties and on such terms as agreed to by them.
- b. For further details on Risk Purchase, you may refer Purchase Manual by accessing BEML website www.bemlindia.in.

25.0 The suppliers will be responsible for the material to reach destination intact and transit insurance shall be arranged by them only. Delivery indicated in the tender enquiry is to be adhered to.

a. In case of late deliveries BEML reserves the right to return the material to vendor. Late supplies may be accepted by BEML if required for production by imposing L clause.

b. Wherever painting is applicable, the surface shall be duly prepared and painted as per drawing requirements.

c. Suitable identification marks to be provided on all components for part number, vendor code, batch no, wherever applicable.

BEML reserves the right to inspect vendor's facilities/components under manufacturing, for verification of process and manufacturing capabilities by BEML's customer/BEML Representative / Representative of agencies appointed by BEML.

Packing to be in such a way that it should avoid transit/storage/handling damage.

If you are not able to quote, please send your Regret Letter with reasons for regretting Refer BEML Purchase Manual (can be accessed in BEML website www.bemlindia.in) for Important terms and conditions of tender and General Terms & conditions applicable to contracts & purchase orders refer General Terms & Conditions. In case Bidder has entered into Rate Contract with DGS&D, the Rate Contract, reference to be sent to BEML along with the quotation. Bidder is required to certify that prices quoted are the same as applicable to DGS&D and other Government Departments. DGS&D Rate Contract holders should state whether they are agreeable for supply at DGS&D Rate Contract Rates in the event of placement of order by us on BEML's own order form. The firm shall take necessary permission for their employees to enter the factory premises and the firm shall arrange ESI & PF coverage to their employees/labourers if any from their end. The firm shall indicate ESI NUMBERS for the labourers hired or employed in advance in order to prepare work permit inside the factory. BEML will not have any kind of binding towards the compensation on case of injury / death to the firms employees while working in BEML premises or other wise. BEML will not have any kind of binding on damages or loss to the tools/instruments etc. brought by the firm for commissioning purpose

We request you to submit your lowest non-negotiable best competitive price.

Division of Patronage : BEML reserves to issued orders on 60:40 ratio basis or 50:30:20 basis

BEML reserves the right to avail the price offered for full quantity of the tender or part thereof or ignore the offer completely without assigning any reason whatsoever. BEML also reserves

the right to increase the order quantity at the same rates and terms and conditions during the pendency of the contract.

The quoted prices should be firm and fixed for the entire shipments, unless otherwise agreed specifically in the contract with breakup of statutory levies if applicable.

Installation and commissioning to be done by supplier at BEML site and bidder to indicate the period required for the above job from the date of intimation of readiness of site at our premises.

The vendor may visit our works with prior intimation & confirmation from our end to study existing facility BEML.

No representation would be entertained on any error(s) if found in the NIT. However, vendor(s) shall bring such errors / omissions to notice of BEML for necessary corrective action(s). The vendor's time and expenses has to be borne by vendor(s).

26.0 PACKING AND DISPATCH

The supplier shall package the deliveries safely and carefully and pack them suitably in all respects considering the peculiarity of the material for normal safe transport by Sea / Air / Rail / Road to its destination suitably protected against loss, damage, corrosion in transit and the effect of tropical salt laden atmosphere. The packages shall be provided with fixtures / hooks and sling marks as may be required for easy and safe handling by mechanical means.

The packing, shipping, storage and processing of the delivery must comply with the prevailing legislation and regulations concerning safety, the environment and working conditions. Items packed with raw / solid wood packing material shall be treated as per ISPM – 15 (fumigation) and accompanied by Phytosanitary / Fumigation certificate. If safety information sheets exist for a delivery or the packaging, the Supplier must always supply these sheets direct (at the same time).

The Supplier shall inform the Purchaser one month in advance of likely shipment date/s, the no. of packages, Gross weight & Net weight, Dimensions (LxBxH) of each of the packages. Each such package must be marked with Consignee name, P.O. Number, Package No., Gross weight & Net weight, dimensions (LxBxH) and Supplier's name. The packing shall allow for easy removal and checking of goods on receipt and comply with carrier's conditions of packing or established trade practices. Packing list of goods inside each package with PO item no., & Quantity must also be fixed securely outside the box to indicate the contents. If any consignment needs special handling instruction, the same shall be clearly marked with standard symbols / instructions. Hazardous material shall be notified such and their packing, transportation and other protection must conform to relevant regulations.

27.0. APPROPRIATION: BEML Ltd., shall be entitled to recover by appropriating in part or full any sum of money payable by the contractor under this contract or any other contract including contracts with other divisions of BEML. Shall the sum of amount recovered is not sufficient to cover the total amount due, BEML is entitled to recover such amount from the bills that becomes due or the contractor shall pay BEML the balance due.

28.0 APPLICABLE LAWS AND JURISDICTION OF COURTS: Indian laws both substantive and procedure, for the time being in force including modifications thereto, shall govern

Contract. The competent Indian courts of shall have sole jurisdiction over disputes between purchaser and the Supplier.

29.0 INTELLECTUAL PROPERTY RIGHTS; LICENSES: If any Patent design, trademark or any other intellectual property rights apply to the delivery or accompanying documentation, Purchaser shall be entitled to the legal use thereof free of charge by means of anon-exclusive, worldwide, perpetual license. All intellectual property rights that arise due to the execution of the delivery by the Supplier and by its employees or third parties involved by the Supplier for performance of the agreement belong to Purchaser. The Supplier shall be obligated to do everything necessary to obtain or establish the above mentioned rights. The Supplier guarantees that the delivery does not infringe on any of the intellectual property rights of third parties. The Supplier shall also be obligated to do everything necessary to obtain or establish the alternate acceptable arrangement pending resolution of any (alleged) claims by third parties.

The supplier shall indemnify the Purchaser against any (alleged) claims by third parties in this regard and shall reimburse Purchaser for any damages suffered as a result thereof. The Contractor shall comply with all requirements under various administrative orders and statutes including but not limited to Contract Labor (Regulation and Abolition) Act, 1970, Employees Provident Fund and Misc. Provisions Act, 1952, Employees' State Insurance Act, 1948, Minimum Wages Act 1948, Payment of Wages Act, 1936, Payment of Bonus Act, 1965, Payment of Gratuity Act, 1972, Employees Compensation Act, 1923, Employers Liability Act 1938, Industrial Disputes Act, 1947, Factories Act, 1948, Shops & Establishment Act (relevant to the State), Child Labor (Prohibition & Regulation) Act, 1986, Sexual Harassment of Women at Workplace (Prevention, Prohibition and Redressal) Act, 2013, Mines Act, 1957 or any other relevant Acts or enactments relating thereto and its amendments (State/Central) and rules framed there under from time to time as may be relevant while performing the obligations under this agreement. Rules framed therein from time-to-time and the Supplier shall indemnify BEML for any loss caused to it by reason of inaction, non-compliance etc., of the provisions of any Law by the Supplier”.

30.0 BRIBES AND GIFTS: Any bribe, commissions, gift or advantage given, promised or offered by or on behalf of the supplier or his partner, agent or servant or anyone on his or on their behalf to any officer, servant, representative or agent of BEML or any person on his or their behalf in relation to the obtaining or to the execution of or any other contract with BEML Ltd., shall in addition to any criminal liability which the supplier, may incur, subject the supplier to the cancellation of this and all other contracts with BEML and also for payment of any loss or damage resulting from any such cancellation to like extent, as is provided in case of cancellation under clause – 12 hereof. Any question or dispute as o the commissions of any offence under the present clause shall be settled by BEML in such manner and on such evidence of information as they may think fit and sufficient and their decision shall be final and conclusive.

31.0 JURISDICTION: Courts of Bangalore alone shall have jurisdiction to decide any issue / dispute arising out of the Arbitration or this Purchase Order in exclusion of all other Courts. However, jurisdiction of any other court may be accepted by mutual discussion and agreement by and between BEML and the Supplier.

32.0. ARBITRATION: Disputes if any, arising between BEML and the supplier in connection with this Purchase Order or any other matters connected herewith, the same will be mutually discussed and settled, failing which, the disputes shall be referred to a sole arbitrator to be appointed by BEML. The arbitration / proceedings shall be in accordance with the provisions of Arbitration and Conciliation Act 1996 and Rules framed there under. The place of arbitration shall be at Bangalore or any other place mutually decided by and between BEML and the supplier and all arbitration proceedings shall be conducted in English language. The award of the sole arbitrator shall be final and binding on all the parties.

33.0 FORCE MAJEURE CLAUSE: Notwithstanding anything contained in the Contract, neither the Supplier nor the Purchaser shall be held responsible for total or partial non-execution of any of the contractual obligations, shall the obligation become unreasonably onerous or impossible due to occurrence of a 'Force Majeure' conditions which directly affect the obligations to be performed by the Purchaser or the Supplier.

Such events include war, military operations of any nature, blockages, revolutions, insurrections, riots, civil commotions, insurgency, sabotage, acts of public enemy, fires, explosion, epidemics, quarantine restrictions, floods, earthquake, or acts of God, restrictions by Govt. authorities over which the Supplier or the acts on which the Purchaser has no control.

The party claiming to be affected by Force Majeure shall notify the other party in writing without delay, within two weeks on the intervention and on the cessation of such circumstance. Extension of time sought by the Supplier along with supporting evidence and so granted by the Purchaser for the supply / work affected, if any, shall not be construed as waiver in respect of remaining deliveries.

Notwithstanding above provisions, Purchaser shall reserve the right to cancel the order/ Contract, wholly or partly, in order to meet the overall delivery schedule and make alternative arrangements including arrangements with third party for completion of deliveries and other schedules. Purchase may takeover partly processed material at a mutually agreed price.

34.0 DRAWINGS AND DOCUMENTS: Drawings, technical documents or other technical information received by one party shall not, without the consent of the other party, be used for any other purpose than that for which they were provided. They may not, without the consent of the submitting party, otherwise be used or copied, reproduced, transmitted or communicated to third parties. The supplier shall, as per agreed date/s but not later than the date of delivery, provide free of charge information and drawings which are necessary to permit the Purchaser to erect, commission, operate and maintain the product. All intellectual properties, including designs, drawings and product information etc. exchanged during the formation and execution of the Contract shall continue to be the property of the submitting party.

35.0 NON DISCLOSURE AND INFORMATION OBLIGATIONS:

The supplier shall provide Purchaser with all information pertaining to the delivery in so far as it could be of importance to Purchaser. The Supplier shall not reveal confidential information to its own employees not involved with the tender / Contract & its execution and delivery or to third parties. The supplier shall not be entitled to use the Purchaser's name in advertisements and other commercial publications without prior written permission from Purchaser.

36.0.AGENTS / AGENCY COMMISSION : The seller confirms and declares to the buyer that the seller is the original manufacturer or authorized distributor / stockiest of original manufacturer or Govt. Sponsored / Designated Export Agencies (applicable in case of countries where domestic laws do not permit direct export by OEMS) of the stores referred to in this offer / contract / Purchase order and has not engaged any individual or firm, whether Indian or Foreign whatsoever, to intercede, facilitate or in any way to recommend to Buyer or any of its functionaries, whether officially or unofficially, to the award of the contract / purchase order to the Seller; nor has any amount been paid, promised or intended to be paid to any such individual or firm in respect of any such intercession, facilitation or recommendation. The Seller agrees that if it is established at any time to the satisfaction of the Buyer that the present declaration is in any way incorrect or if at a later stage it is discovered by the Buyer that the Seller has engaged any such individual / firm, and paid or intended to pay any amount, gift, reward, fees, commission or consideration to such person, party, firm or institution, whether before or after the signing of this contract / purchase order, the Seller will be liable to refund that amount to the Buyer. The Seller will also be debarred from participating in any RFQ / Tender for new projects / program with Buyer for a minimum period of five years. The Buyer will also have a right to consider cancellation of the Contract / Purchase order either wholly or in part, without any entitlement or compensation to the Seller who shall in such event be liable to refund all payments made by the Buyer in terms of the Contract / Purchase order along with interest at the rate of 2% per annum above LIBOR (London Inter Bank Offer Rate) (for foreign vendors) and Base Rate of SBI (State Bank of India) plus 2% (for Indian vendors). The Buyer will also have the right to recover any such amount from any contracts / Purchase order concluded earlier with Buyer.

37.0.FALL CLAUSE:

- i. The prices charged for the stores supplied under this P.O by the supplier shall in no event exceed the lowest price at which the supplier sells the stores of identical description to any other BEML Office / Division during the pendency of this PO.
- ii. If at any time, during the said period, the supplier reduces the sale price of such stores or sells such stores to any other BEML Office / Division at a price lower than the price chargeable under this P.O and the price payable under this PO for the stores supplied after the date of coming into force of such reduction shall stand correspondingly reduced.

38.0 DURING ARBITRATION: "Supplies under this Purchase Order, if reasonably possible, may continue by mutual agreement during the dispute / Arbitration proceedings".

39.0 CONTRACT VARIATIONS: INCREASE OR DECREASE IN THE SCOPE OF SUPPLY: Purchaser may vary the contracted scope. If the supplier is of the opinion that the variation in scope has an effect on the agreed price or delivery period, purchaser shall be informed of this immediately in writing along with technical details, and in the event of additional work, submit a quotation with regards to the price and delivery period and the effect this scope will have on the other contracts under execution by the supplier. The supplier shall not perform additional

work / altered scope of work without the written instructions / amendment to the Purchase Order to that effect. The Purchaser also reserves its rights to decrease the scope of supply placed against Purchase Orders under due intimation to the supplier. Such decrease may be warranted due to defective goods or Policy Decisions of the Management of the Purchaser. And in such an event, the Supplier shall not have any claims or right against the Purchaser.

40.0 NON-WAIVER OF DEFAULTS: If any individual provision of the Contract is invalid the other provisions shall not be affected. The failure of BEML to insist upon performance of the Contract to enforce any of the terms and conditions of this Contract or to exercise any right or privilege granted to BEML under this Contract or under law shall not be construed as a waiver and the same shall continue in full force and effect.

41.0.ASSIGNMENT OF RIGHTS AND OBLIGATIONS; SUBCONTRACTING: The supplier is not permitted to sub-contract the delivery or any part thereof to third parties or to assign the rights and obligations resulting from this agreement in whole or in part to third parties without prior written permission from Purchaser. Any permission or approval given by the Purchaser shall, however, not absolve the supplier of the responsibility of his obligations under the contract.

42.0 INTEGRITY COMMITMENT IN THE EXECUTION OF CONTRACTS:

Commitment by Purchaser:

Purchaser commits to take all necessary steps to prevent corruption in connection with the execution of the Contract.

Commitment by the Contractor:

The Contractor (s) commit (s) to take all measures to prevent corruption and will not directly or indirectly try to influence any decision for the benefit for which he is not legally entitled.

The contractor (s) will not commit any offence under the relevant Acts. The Contractor(s) will not use improperly, for purpose of competition or personal gain or pass on to others, any information or documents provided by Purchaser as part of business relationship.

The Contractor (s) will not enter with other Bidder(s) / Contractor(s) into any undisclosed agreement or understanding or any actions to restrict competition. If the Contractor (s), before award or during execution of the Contract commit (s) a transgression of the above or in any other manner such as to put his reliability or credibility in question, Purchaser is entitled to disqualify the contractor (s) from the tender process or terminate the contract and / or take suitable actions as deemed fit.

43.0SECRECY:

- a) All the information, know-how, technical data, specification and drawing models or specimens furnished by BEML for the purpose of or in connection with the manufacture and supply of the stores hereby tendered constitute the property of BEML and the supplier shall keep them in strict confidence and he shall not divulge the same to anyone else except under the authority and for the purpose of BEML. All such documents, data, drawing, models and specimens are the property of BEML and shall be returned when done with or when demanded by BEML.

b) The supplier shall not supply the material ordered by BEML to anyone else other than BEML and shall not disclose any initiations, development or adaptations thereof to anyone else except with the written consent of BEML.

c) BEML shall be entitled to prevent a breach of the above and to damages in case of breach. In case of non-performance in the PO, BEML will take procurement action at your risks and cost apart from levying liquidated damages.

44.0 INSTRUCTION FOR SUBMISSION INTEGRITY PACT (If estimated value > Rs. 1 Crore)

1. The bidder / contractor should submit duly signed **Integrity Pact** (if the tender value is more than Rs.1.00 crore) as Pre-Qualification documents in single sealed envelope. The sealed envelope containing pre-qualification documents shall be duly super scribed at the top of the envelope with "Pre-Qualification Bid to Tender Ref: _____ (Bid invitation number) due on _____ (Tender closing date)for " _____ " (Description of service). The name and address of the tenderer shall be written on the left hand bottom corner of the envelope. The bidder should submit Pre-Qualification Bid through manual mode to the following address before tender closing date & time.

(Address of Office where bid to be submitted)

Also Copy of Integrity pact to be uploaded along with bid.

2. The bidder has to execute and submit 'Integrity Pact' on plain paper for all tenders of value Rs 1 Crore and above as per prescribed format to this tender document. This integrity pact is a preliminary qualification in entering in to any contract with BEML Limited. For the successful bidder, the integrity pact will remain valid up to 12 months after the last payment under the contract, and for all other Bidders 6 months after the contract has been awarded. Offers without Integrity Pact duly signed will be disqualified (Pls refer our Purchase Manual page no 247 (Annexure-J) available in our website :<https://www.bemlindia.in>). The bidder should put their authorized signature in the Integrity pact as a Contractor / bidder with their company seal along with witness's signature, name & address.

3. The Central Vigilance Commission (CVC) has appointed Shri Akhilesh Kumar , CES (Retd.) & Shri E.K Bharat Bhushan, IAS (retd.) as Independent External Monitor (IEM) to oversee the implementation of the Integrity Pact.

Address of IEM is as below:-

1. Shri Akhilesh kumar, CES (Retd.)

Flat No.3111

Tower Osimo , Mahagun Mezzaria

Sector 78, Noida. U.P 201304

Mobile no.09811420440

Email : er.akhilesh@yahoo.co.in

2. Shri E.K Bharat Bhushan, IAS (Retd.)

Flat no 5151, Sobha city, Puzhukkal,

Thrissur, Kerala-680553

Mobile no : +91 9400797777

Email ID : bbhushan55@gmail.com

45.0. GST TERMS & CONDITIONS

The Supplier is required to comply with all the applicable provisions of the GST Laws/Rules/Notifications/Circulars and to furnish required documents/details within the prescribed time limit to enable BEML to claim the benefits of GST Input Tax Credit or any other benefit.

1. The Supplier is required to furnish proper Invoice/Supplementary Invoice/Debit Note/Credit Note in the form and manner prescribed under GST Laws/Rules/Notifications/Circulars containing all the particulars mentioned therein and within the prescribed time limit as per prevailing GST Laws/Rules/Notifications/Circulars. In case of non-compliance by the Supplier, BEML shall not make any payment towards GST against such invoice until it is complied with within the timeline prescribed under GST Laws/Rules/Notifications/Circulars, and also subject to BEML being in a position to avail GST Input Tax Credit as per applicable GST Laws/Rules/Notifications/Circulars.
2. In case of discrepancy in the data uploaded by the Supplier in the GSTN portal or in case of any shortages or rejection in the supply, BEML will notify the Supplier of the same. Supplier has to rectify the data discrepancy in the GSTN portal or issue Credit note (details to be uploaded in GSTN portal) for the shortages or rejections in the supplies, within the prescribed time limit to enable BEML to avail GST Input Tax Credit.
3. In case, the availment of GST Input Tax Credit by BEML is delayed for any reason other than those attributable to BEML, interest at applicable rate as prescribed under GST Laws/Rules/Notifications/Circulars for such delays shall be recovered from the Supplier.
4. In case Supplier delays declaring such invoice in his GST Return and GST Input Tax Credit availed by BEML is denied or reversed subsequently as per GST Laws/Rules/Notifications/Circulars, GST amount paid by BEML towards such reversal as per GST Laws/Rules/Notifications/Circulars shall be recoverable from Supplier along with applicable interest.
5. If BEML has not paid/short paid to the Supplier for any invoices within the time limit prescribed under GST Laws/Rules/Notifications/Circulars due to non-compliance of GST Laws/Rules/Notifications/Circulars by Supplier or any other reason attributable to Supplier and leads to any GST Input Tax Credit reversal by BEML, any losses/expenses/cost/penalty, etc incurred by BEML shall be recoverable from the Supplier.
6. Wherever applicable, BEML will have the right to deduct "Tax Deducted at Source" at the rate prescribed under the GST Laws/Rules/Notifications/Circulars and to remit the same to the Government.
7. In case of supplies made under Reverse Charge Mechanism, the Supplier needs to comply with the provisions under the GST Laws/Rules/Notifications/Circulars in terms of supply of Goods/Services and raising of invoice, so as to enable BEML to remit applicable GST to Govt., within the prescribed time limit and avail GST Input Tax Credit on the same. If the Supplier fails to comply with the above and as a result if BEML incurs any losses/expenses/cost/penalty, BEML shall be entitled to recover the same from the Supplier. Further the Supplier has to mention that "the liability of payment of GST amounting to Rs is on the Recipient of Service" in the invoice raised on BEML.
8. The Supplier is required to comply with the E-Way Bill Provisions under GST Laws/Rules/Notifications/Circulars. If the Supplier fails to comply with the said

provisions and as a result if BEML incurs any losses/expenses/cost/penalty, BEML shall be entitled to recover the same from the Supplier.

9. In case of materials/goods issued to Supplier for Job Work, the Job Work Supplier is required to return the goods within the time limit prescribed in the Purchase Order. If the Job Work Supplier fails to return the goods as above, BEML will be entitled to raise a GST Supply Invoice on the Job Worker Supplier with applicable interest as per the provisions of GST Laws/Rules/Notifications/Circulars. In such cases, BEML will be entitled to recover all such GST/interest on GST /losses/expenses/cost/penalty, etc. incurred by BEML along with interest from the Job Work Supplier. Further in such cases where the GST invoice has been raised by BEML, on return of such goods after the prescribed time limit, the Job Work Supplier needs to return the same under GST invoice.
10. GST portion of the invoice shall be released only upon the Supplier declaring such invoice in his GST Return and payment of GST thereof to appropriate government and satisfying all the conditions mentioned above. However, in case the Supplier wishes to obtain the payment of GST portion also along with the payment of the base value of the invoice, Supplier has the option to submit Bank Guarantee of an amount equivalent to the GST portion of the invoice plus 3 months' interest at prevailing rate of interest under GST Laws/Rules/Notifications/Circulars as applicable in case of reversal of GST Input Tax Credit. Such Bank Guarantee shall be valid till 30th September of the next financial year or filing of GST Annual Return by Supplier/Vendor (for which such invoice pertains to), whichever is earlier. BEML will release Bank Guarantee only when the Supplier declaring such invoice in his GST Return and remittance of GST thereon to the Govt. In case the Supplier fails to fulfill the required conditions resulting in BEML not been able to avail GST Input Tax Credit Bank Guarantee shall be encashed and such GST amount along with interest and any other cost/loss incurred by BEML shall be recoverable from Supplier.
11. The Supplier have the option to give one Bank Guarantee of appropriate value after considering his estimated value of GST involved in invoices raised on BEML instead of Bank Guarantee for each Contract/Invoice. In case of payment through LC, suitable provisions/clause will be inserted while opening LC to ensure compliances of above conditions. However, if at any point of time value of such Bank Guarantee falls short of GST plus interest thereof, Supplier will have to either furnish Bank Guarantee for Differential value or such shortfall value of Bank Guarantee vis-à-vis GST plus interest thereof shall be withheld till Suppliers fulfils its obligations specified under above clauses.
12. BEML will be entitled to recover all losses/expenses/cost/penalty, etc. incurred by BEML along with applicable interest from the Supplier due to reasons other than those attributable to BEML.
13. If the Supplier is a Composition/Unregistered Dealer, the Supplier needs to comply with the provisions under the GST Laws/Rules/Notifications/Circulars in terms of supply of Goods/Service and raising of invoice. In case, the Supplier fails to comply with the above and as a result if BEML incurs any losses/expenses/cost/penalty, BEML shall be entitled to recover the same from the Supplier along with applicable interest.

SPECIAL TERMS AND CONDITIONS FOR FOREIGN TENDER

1. The prices shall be on CIF basis and shall include packing & forwarding charges. If any other incoterms is quoted, suitably loading will be done for arriving L1 offer.
2. Quote should also indicate the Minimum lead time, MAKE, Country of Origin & Ex-stock availability.
3. Payment term:
 - a. For Overseas suppliers: The payment shall be on collection basis, on the 60th day of negotiation at Bank or on the 60th day of invoice or LC with 60 days credit. All Banking charges within India to BEML's account and outside India shall be to your account. For Bidders not agreeing with the above terms, their quotations will be suitably loaded with applicable cash credit interest while evaluation of bids.
 - b. For Timely payments, the concerned purchase/ finance department at BEML Divisions will communicate to the supplier within 7 days from the date of receipt of Invoice for processing, may seek clarification / missing documents required. Similarly suppliers are also required to reply for all clarification / submit all missing documents within 7 days from the date of receipt of communication.
 - c. In case of LC payment LD Clause will be incorporated.
 - d. Advance payment will not be done.
4. Maximum possible quantity supply per month to be indicated in the quotation in case of capacity constraint.
5. Supplies should be strictly as per the requirement projected. The item supplied should be GENUINE PART as it is used for OE requirement.
6. If the supplier exceeds any agreed delivery date(s) or period(s), Purchaser shall levy LD (Liquidated Damaged) for such delay at the rate of 0.5% per week(7 days) and part thereof ,subject to maximum of 5% of the value of the delayed portion of the purchase order.
7. In case of early supplies, payment will be made only as per the delivery schedule indicated in the purchase order and payment will be released from the date of bill of lading/bill of entry and in line with the terms of payment.
8. Packing to be in such a way that it should seaworthy and airfreight shipment avoid transit/storage/handling damage.
9. Along with supplies it is required to submit: Inspection certificate, warranty certificate, Country of Origin certificate & other related documents required along with the shipment.
10. This tender is governed by the General terms & conditions of BEML.